

Positive Displacement Pumps—Rotary

API STANDARD 676
FOURTH EDITION, FEBRUARY 2022



Special Notes

API publications necessarily address problems of a general nature. With respect to particular circumstances, local, state, and federal laws and regulations should be reviewed. The use of API publications is voluntary. In some cases, third parties or authorities having jurisdiction may choose to incorporate API standards by reference and may mandate compliance.

Neither API nor any of API's employees, subcontractors, consultants, committees, or other assignees make any warranty or representation, either express or implied, with respect to the accuracy, completeness, or usefulness of the information contained herein, or assume any liability or responsibility for any use, or the results of such use, of any information or process disclosed in this publication. Neither API nor any of API's employees, subcontractors, consultants, or other assignees represent that use of this publication would not infringe upon privately owned rights.

API publications may be used by anyone desiring to do so. Every effort has been made by the Institute to ensure the accuracy and reliability of the data contained in them; however, the Institute makes no representation, warranty, or guarantee in connection with this publication and hereby expressly disclaims any liability or responsibility for loss or damage resulting from its use or for the violation of any authorities having jurisdiction with which this publication may conflict.

API publications are published to facilitate the broad availability of proven, sound engineering and operating practices. These publications are not intended to obviate the need for applying sound engineering judgment regarding when and where these publications should be used. The formulation and publication of API publications is not intended in any way to inhibit anyone from using any other practices.

Any manufacturer marking equipment or materials in conformance with the marking requirements of an API standard is solely responsible for complying with all the applicable requirements of that standard. API does not represent, warrant, or guarantee that such products do in fact conform to the applicable API standard.

All rights reserved. No part of this work may be reproduced, translated, stored in a retrieval system, or transmitted by any means, electronic, mechanical, photocopying, recording, or otherwise, without prior written permission from the publisher. Contact the Publisher, API Publishing Services, 200 Massachusetts Avenue, NW, Suite 1100, Washington, DC 20001-5571.

Foreword

Nothing contained in any API publication is to be construed as granting any right, by implication or otherwise, for the manufacture, sale, or use of any method, apparatus, or product covered by letters patent. Neither should anything contained in the publication be construed as insuring anyone against liability for infringement of letters patent.

The verbal forms used to express the provisions in this document are as follows.

Shall: As used in a standard, “shall” denotes a minimum requirement to conform to the standard.

Should: As used in a standard, “should” denotes a recommendation or that which is advised but not required to conform to the standard.

May: As used in a standard, “may” denotes a course of action permissible within the limits of a standard.

Can: As used in a standard, “can” denotes a statement of possibility or capability.

This document was produced under API standardization procedures that ensure appropriate notification and participation in the developmental process and is designated as an API standard. Questions concerning the interpretation of the content of this publication or comments and questions concerning the procedures under which this publication was developed should be directed in writing to the Director of Standards, American Petroleum Institute, 200 Massachusetts Avenue, NW, Suite 1100, Washington, DC 20001. Requests for permission to reproduce or translate all or any part of the material published herein should also be addressed to the director.

Generally, API standards are reviewed and revised, reaffirmed, or withdrawn at least every five years. A one-time extension of up to two years may be added to this review cycle. Status of the publication can be ascertained from the API Standards Department, telephone (202) 682-8000. A catalog of API publications and materials is published annually by API, 200 Massachusetts Avenue, NW, Suite 1100, Washington, DC 20001.

Suggested revisions are invited and should be submitted to the Standards Department, API, 200 Massachusetts Avenue, NW, Suite 1100, Washington, DC 20001, standards@api.org.

Contents

	Page
1 Scope.....	1
2 Normative References	1
3 Terms and Definitions	4
4 General	10
4.1 Unit Responsibility	10
4.3 Pump Designations.....	10
5.1 [●] Units of Measure.....	16
5.2 Statutory Requirements	16
5.3 Documentation Requirements	16
6 Basic Design	16
6.1 General	16
6.2 Selection and Rating of Pump Type.....	19
6.3 Pressure-containing and Pressure-retaining Parts	19
6.4 Casing Connections.....	20
6.5 Auxiliary Connections	21
6.6 Flanges	22
6.7 External Forces and Moments.....	23
6.8 Rotating Elements	25
6.9 Mechanical Shaft Seals	26
6.10 Bearings and Bearing Housings	27
6.11 Vibration Limits	28
6.12 Lubrication	29
6.13 Materials	30
6.14 Nameplates and Rotation Arrows	36
7 Accessories	36
7.1 Drivers	36
7.2 Couplings and Guards	38
7.3 Belt Drives	40
7.4 Baseplates	41
7.5 Pressure-limiting Valves (PLVs).....	43
7.6 Controls and Instrumentation.....	44
7.7 Auxiliary Piping	44
7.8 Pulsation and Vibration Control Requirements for Multiphase Skids.....	44
7.9 Special Tools.....	44
8 Inspection, Testing, and Preparation for Shipment	45
8.1 General	45
8.2 Inspection	45
8.3 Testing	47
8.4 Preparation for Shipment.....	51
9 Vendor's Data	52
9.1 General	52
Annex A (informative) Rotary Pump Datasheets	53

Contents

	Page
Annex B (informative) Factors Affecting Twin Screw Pump Wear Rate and Volumetric Efficiency	64
Annex C (informative) Inspector's Checklist.....	69
Annex D (informative) Contract Documents and Engineering Design Data.....	71
Annex E (informative) Rotary Pump Vendor Drawing and Data Requirements (VDDRs).....	76
Annex F (informative) Net Positive Suction Head (NPSH) vs Net Positive Inlet Pressure (NPIP)	88
Annex G (informative) Typical P&D for MPP Pumps.....	90
Bibliography.....	91

Figures

1	Sliding Vane Pump (Vane in Rotor)	11
2	Single Lobe Pump	11
3	Three Lobe Pump	12
4	External Gear Pump	12
5	Internal Gear Pump	12
6	Progressing/Progressive Cavity Pump (PCP)	13
7	Twin Screw Pump (with Timed Gears).....	13
8	Three-screw Pump (with Untimed Gears)	13
9	Rotary Pump Consolidated Range Chart (Typical Range in SI Units).....	14
10	Rotary Pump Consolidated Range Chart (Typical Range in USC Units).....	15

Tables

1	Pump Classification Type Identification	10
2	Nozzle Loadings	23
3	Welding Requirements.....	34
4	Material Inspection Standards	46
5	Test Tolerances.....	50
C.1	Inspector's Checklist.....	69

Introduction

This standard is based on the accumulated knowledge and experience of manufacturers and users of rotary positive displacement pumps. The objective of this standard is to provide a purchase specification to facilitate the procurement and manufacturer of rotary positive displacement pumps for use in petroleum, chemical, and gas industry services.

The primary purpose of this standard is to establish minimum requirements. This limitation in scope is one of charter as opposed to interest and concern.

Energy conservation is of concern and has become increasingly important in all aspects of equipment design, application, and operation. Thus innovative, energy-conserving approaches should be aggressively pursued by the manufacturer and the user during these steps. Alternative approaches that may result in improving energy utilization should be thoroughly investigated and brought forth. This is especially true of new equipment proposals, since the evaluation of purchase options will be based increasingly on total life costs as opposed to acquisition cost alone. Equipment manufacturers, in particular, are encouraged to suggest alternatives to those specified when such approaches achieve improved energy effectiveness and reduced total life costs without sacrifice of safety or reliability.

This standard requires the purchaser to specify certain details and features. Although it is recognized that the purchaser may desire to modify, delete, or amplify sections of this standard, it is strongly recommended that such modifications, deletions, and amplifications be made by supplementing this standard, rather than by rewriting or incorporating sections thereof into another standard.

API standards are published as an aid to procurement of standardized equipment and materials. These standards are not intended to inhibit purchasers or producers from purchasing or producing products made to other standards.

Positive Displacement Pumps—Rotary

1 Scope

This standard covers the minimum requirements for rotary positive displacement process pumps and pump units for use in the petroleum, petrochemical, and gas industry services. Controlled-volume pumps, hydraulically driven pumps and positive displacement reciprocating pumps are not included (see API 674 for positive displacement reciprocating pumps and API 675 for controlled-volume pumps).

For rotary positive displacement pumps in auxiliary services (e.g. lube oil systems), manufacturer's standard with demonstrated experience is acceptable.

- Annex A contains datasheets which purchasers are encouraged to use (informative).
- Annex B provides guidance for factors affecting twin screw efficiencies (informative).
- Annex C contains an inspector's checklist (informative).
- Annex D contains information on Contract Documents and Engineering Design Data (informative)
- Annex E contains forms which may be used to indicate vendor drawing and data requirements (VDDRs) (informative).
- Annex F gives guidance regarding net positive suction head (NPSH) vs net positive inlet pressure (NPIP) (informative).
- Annex G provides a typical P&ID for multiphase pump skids (informative).

This standard requires the purchaser to specify certain details and features. A bullet [•] at the beginning of a paragraph indicates that either a decision by, or further information from, the purchaser is required. Further information should be shown on the datasheets (see example in Annex A) or stated in the quotation request and purchase order.

2 Normative References

The following referenced documents are indispensable for the application of this document. For dated references, only the edition cited applies. For undated references, the latest edition of the referenced document (including any amendments) applies.

API Recommended Practice 500, *Recommended Practice for Classification of Locations for Electrical Installations at Petroleum Facilities Classified as Class I, Division 1, and Division 2*

API 500, *Classification of Locations for Electrical Installations in Petroleum Refineries*

API Recommended Practice 520, *Sizing, Selection, and Installation of Pressure-Relieving Devices in Refineries; Part I—Sizing and Selection*

API Recommended Practice 520, *Sizing, Selection, and Installation of Pressure-relieving Devices in Refineries; Part II—Installation*

API Standard 526, *Flanged Steel Pressure Relief Valves*

API Standard 541, *Form-wound Squirrel-cage Induction Motors—500 Horsepower and Larger*

API Standard 546, *Brushless Synchronous Machines—500 kVA and Larger*

API Standard 547, *General-purpose Form-wound Squirrel-cage Induction Motors—250 Horsepower and Larger*

API Recommended Practice 578, *Material Verification Program for New and Existing Alloy Piping Systems*

API Standard 611, *General-purpose Steam Turbines for Petroleum, Chemical, and Gas Industry Services*

API Standard 613, *Special Purpose Gear Units for Petroleum, Chemical, and Gas Industry Services*

API Standard 614, *Lubrication, Shaft-sealing, and Control-oil Systems and Auxiliaries*

API Standard 671, *Special Purpose Couplings for Refinery Services*

API Standard 677, *General-Purpose Gear Units for Petroleum, Chemical and Gas Industry Services*

API Standard 682, *Pumps—Shaft Sealing Systems for Centrifugal and Rotary Pumps*

API Recommended Practice 686, *Machinery Installation and Installation Design*

API Recommended Practice 688, *Pulsation and Vibration Control in Positive Displacement Machinery Systems*

API Standard 691, *Risk-based Machinery Management*

ABMA 7,¹ *Shaft, Housing Fits for Metric Radial Ball and Roller Bearings (Except Tapered Roller Bearings) Conforming to Basic Boundary Plans*

ABMA 9, *Load Ratings and Fatigue Life for Ball Bearings*

ABMA 11, *Load Ratings and Fatigue Life for Roller Bearings*

ABMA 20, *Radial Bearings of Ball, Cylindrical Roller and Spherical Roller Types - Metric Design*

AGMA 6013, *Standard for Industrial Enclosed Gear Drives*

AGMA 6091, *Standard for Gearmotor, Shaft Mounted and Screw Conveyor Drives*

AGMA 9000, *Flexible Couplings—Potential Unbalance Classification*

AGMA 9002, *Bores and Keyways for Flexible Couplings (Inch Series)*

ASA S2.19,² *Mechanical Vibration—Balance Quality Requirements of Rigid Rotors—Part 1: Determination of Permissible Residual Unbalance, Including Marine Applications*

ASME. *Boiler and Pressure Vessel Code (BPVC),³ Section V: Non-destructive Examination*

ASME. *BPVC, Section VIII: Pressure Vessels; Division 1*

ASME. *BPVC, Section IX: Welding and Brazing Qualifications*

ASME B1.1, *Unified Inch Screw Threads (UN and UNR Thread Form)*

ASME B1.20.1, *Pipe Threads, General Purpose (Inch)*

ASME B16.1, *Gray Iron Pipe Flanges and Flanged Fittings (Classes 25, 125 and 250)*

¹ American Bearing Manufacturers Association, 2025 M Street, NW, Suite 800, Washington, DC 20036, www.abma-dc.org.

² American Subcontractors Association, 1004 Duke Street, Alexandria, Virginia 22314, www.asaonline.com.

³ ASME International, 3 Park Avenue, New York, New York 10016–5990, www.asme.org.

- ASME B16.5, *Pipe Flanges and Flanged Fittings NPS 1/2 Through NPS 24 Metric/Inch Standard*
- ASME B16.11, *Forged Fittings, Socket Welding and Threaded*
- ASME B16.42, *Ductile Iron Pipe Flanges and Flanged Fittings*
- ASME B16.47, *Large Diameter Steel Flanges*
- ASME B17.1, *Keys and Keyseats*
- ASME B31.3, *Process Piping*
- AWS D1.1,⁴ *Structural Welding Code—Steel*
- DIN 910:2004,⁵ *Heavy-duty Hexagon Head Screw Plugs*
- EN 287,⁶ *Qualification Test of Welders—Fusion Welding*
- EN 953, *Safety of Machinery—Guards—General Requirements for the Design and Construction of Fixed and Movable guards*
- HI 3.1-3.5,⁷ *Rotary Pump Standards for Nomenclature, Definitions, Applications and Operation*
- HI 3.6⁸, *Rotary Pump Test*
- IEC 60079,⁸ *Explosive Atmospheres*
- IEEE 841,⁹ *Standard for Petroleum and Chemical Industry—Severe Duty Totally-enclosed Fan-cooled (TEFC) Squirrel Cage Induction Motors—Up to and Including 370 Kw (500 Hp)*
- ISO 7, *Pipe threads where pressure-tight joints are made on the threads—Part 1: Dimensions, tolerances and designation*
- ISO 7, *Pipe threads where pressure-tight joints are made on the threads—Part 2: Verification by means of limit gauges*
- ISO 228-1, *Pipe threads where pressure-tight joints are not made on the threads—Part 1: Dimensions, tolerances and designation*
- ISO 261, *ISO general-purpose metric screw threads—General plan*
- ISO 262, *ISO general-purpose metric screw threads—Selected sizes for screws, bolts and nuts*
- ISO 724, *ISO general-purpose metric screw threads—Basic dimensions*
- ISO 965, *ISO general-purpose metric screw threads—Tolerances*
- ISO 1940-1, *Mechanical vibration—Balance quality requirements for rotors in a constant (rigid) state—Part 1: specification and verification of balance tolerances*

⁴ American Welding Society, 550 NW LeJeune Road, Miami, Florida 33126, www.aws.org.

⁵ Deutsches Institut für Normung E.V., Burggrafenstrasse 6, 10787 Berlin, Germany, www.din.de.

⁶ European Committee for Standardization, Avenue Marnix 17, B-1000, Brussels, Belgium, www.cen.eu.

⁷ Hydraulic Institute 300 Interpace Parkway, Suite 280, 3rd floor, Parsippany, NJ 07054, www.pumps.org.

⁸ International Electrotechnical Commission, 3 rue de Varembé, PO Box 131, CH-1211, Geneva 20, Switzerland, www.iec.ch.

⁹ Institute of Electrical and Electronics Engineers, 445 Hoes Lane, Piscataway, New Jersey 08854, www.ieee.org.

ISO 3744, *Acoustics—Determination of sound power levels of noise sources using sound pressure—Engineering method in an essentially free field over a reflecting plane*

ISO 5753, *Rolling bearings—Radial internal clearance*

ISO 6708:1995, *Pipework components—Definition and selection of DN (nominal size)*

ISO 7005-1, *Metallic flanges—Steel flanges*

ISO 7005-2, *Metallic flanges—Cast iron flanges*

ISO 8501-1, *Preparation of steel substrates before application of paints and related products—Visual assessment of surface cleanliness—Part 1: Rust grades and preparation grades of uncoated steel substrates after overall removal of previous coatings*

ISO 14120, *Safety of machinery—Guards—General requirement for the design and construction of fixed and movable guards*

ISO 14691, *Petroleum, petrochemical and natural gas industries—Flexible couplings for mechanical power transmission—General-purpose applications*

MSS SP-55, *Quality Standard for Steel Castings for Valves, Flanges, Fittings and Other Piping Components—Visual Method for Evaluation of Surface Irregularities*

NACE MR 0103,¹⁰ *Materials Resistant to Sulfide Stress Cracking in Corrosive Petroleum Refining Environments*

NACE MR 0175, *Materials for Use in H₂S-containing Environments in Oil and Gas Production*

NACE. *Corrosion Engineer's Reference Book*

NFPA 70,¹¹ *National Electrical Code*

SSPC SP 6,¹² *Commercial Blast Cleaning*

2.2 All referenced standards, to the extent specified in the text, are normative.

2.3 Notes are informative, unless contained in a figure or table.

2.4 The editions of standards, codes, and specifications that are in effect at the time of publication of this standard shall, to the extent specified herein, form a part of this standard. The applicability of changes in standards, codes, and specifications that occur after the inquiry shall be mutually agreed upon by the purchaser and the vendor.

3 Terms and Definitions

For the purposes of this standard, the following terms and definitions apply.

3.1

alarm

Preset value of a measured parameter that sends a warning of a condition that requires corrective action.

¹⁰ NACE International (formerly the National Association of Corrosion Engineers), 1440 South Creek Drive, Houston, Texas 77218-8340, www.nace.org.

¹¹ National Fire Protection Association, 1 Batterymarch Park, Quincy, Massachusetts 02169-7471, www.nfpa.org.

¹² The Society for Protective Coatings, 40 24th Street, 6th Floor, Pittsburgh, Pennsylvania 15222, www.sspc.org.

3.2**anchor bolt**

A sleeved stud or threaded bar used to attach the baseplate to the support structure (concrete foundation or steel structure).

3.3**baseplate**

Component on which the drive train and pump are bolted, which is then fastened to the support structure using anchor bolts.

3.4**capacity**

Flowrate i.e. volume per unit time.

3.5**certified material test report****CMTR**

Certified report documenting the actual chemical composition or physical properties of critical materials.

3.6**critical speed**

shaft rotational speed at which the rotor-bearing-support system is in a state of resonance.

3.7**datum elevation**

Elevation to which values of NPSH are referred (concrete foundation or steel structure to which the baseplate is attached); also see paragraph defining NPSH (see 3.39).

3.8**design**

Vendor's calculated parameter.

NOTE A term used by the equipment vendor to describe various parameters such as design power, design pressure, design temperature, or design speed. It is not intended for the purchaser to use this term.

3.9**differential pressure**

Change in energy of the pumped liquid due to its pressure change in the pump. Typically, the discharge pressure minus the suction pressure.

3.10**displacement**

Volume transferred from the suction to discharge per revolution of the rotor(s). In pumps incorporating two or more rotors operating at different speeds, the displacement is the volume transferred per revolution of the driving rotor.

3.11**drive train components**

Item of the equipment used in series to drive the pump (e.g. motor, gear, turbine, engine, fluid drive, clutch).

3.12**gas volume fraction****GVF**

Ratio of volume of gas to that of the total volume of the fluid (oil, water, and gas) at pump suction temperature and pressure, the fraction being expressed as a percentage.

3.13
hold-down bolt
mounting bolt

A fastener, such as a stud with nuts, holding the equipment to the baseplate.

3.14
hydrostatic test pressure

Static test pressure used for leak testing.

3.15
inspection and test plan
ITP

Single project-specific document used to consolidate all inspection and test requirements, acceptance criteria, and roles and responsibilities; typically, with extended scope for heavy duty pumps in complex packages,

3.16
maximum allowable casing pressure
MACP

Maximum pressure for which the vendor has designed the pressure-containment components at the specified operating temperature.

3.17
maximum allowable working pressure
MAWP

Maximum continuous pressure for which the vendor has designed the equipment (or any part to which the term is referred) when handling the specified fluid at the specified maximum operating temperature.

3.18
maximum continuous allowable speed

Highest rotational speed (revolutions per minute) at which the machine, as-built and tested, is capable of continuous operation with the specified fluid at any of the specified operating conditions.

3.19
minimum design metal temperature

Lowest mean metal temperature (through the thickness) expected in service, including operation upsets, auto-refrigeration, and temperature of the surrounding environment.

3.20
multiphase fluid

A process stream comprised of two or more phases where one phase is a gas, and one phase is a liquid and particulate may be present.

3.21
multiphase pump
MPP

Pump designed to successfully handle fluids with at least both gas and liquid present in the process stream.

3.22
net positive inlet pressure
NPIP

Minimum pressure determined at the datum elevation minus the vapor pressure of the fluid at the maximum operating temperature at any specified point.

3.23
net positive inlet pressure available
NPIPA

NPIP determined by the purchaser from the NPSHA and system design data.

3.24**net positive inlet pressure required****NPIPR**

Minimum NPIP required by the pump to achieve the required performance with the specified fluid at any specified point, as determined by vendor.

3.25**net positive suction head****NPSH**

Total absolute suction head determined at the suction nozzle and referred to the datum elevation minus the head of the vapor pressure of the fluid.

NOTE It is expressed as head of water, in feet (meters).

3.26**net positive suction head available****NPSHA**

Minimum value of NPSH determined to be available under any specified operating condition, accounting for line losses, under steady state flow conditions.

NOTE NPSHA is a value provided by the purchaser and which the purchaser uses to calculate the NPIPA (see 3.23). NPSHA is a function only of the system upstream of the pump and the operating conditions and is independent of pump design.

3.27**net positive suction head required****NPSHR**

Minimum value of NPSH determined to be required under any specified operating condition, based on steady state flow.

NOTE NPSHR is a value provided by the vendor by taking the equipment requirements, which are based on the centerline of inlet reference point and adjusting it to the underside of the baseplate. It correlates to the NPIPR (see 3.24).

3.28**nominal pipe size****NPS**

Designation, usually followed by a size number designation number, corresponding approximately to the outside diameter of the pipe expressed in inches.

3.29**nominal pressure****PN**

Numerical designation relating to pressure that is a convenient round number for reference purposes.

3.30**nondestructive testing****NDT**

Inspection of materials, components, or assemblies by means of radiography, liquid penetrant, magnetic particle, or ultrasonic testing (the typical methods employed)

3.31**performance test**

Running test conducted to measure flow rate, differential pressure, and power consumed at specified conditions.

NOTE Test results need to be corrected to service conditions, e.g. viscosity.

3.32**PMI****positive material identification testing**

Any physical evaluation or test of a material to confirm that the material which has been or will be placed into service is consistent with the selected or specified alloy material designated by the owner/user. These evaluations or tests can provide either qualitative or quantitative information that is sufficient to verify the nominal alloy composition.

NOTE Adapted from API RP 578: 2010.

3.33**pressure-containing part**

Any part that acts as a barrier between process or motive fluid and the atmosphere.

3.34**pressure-limiting valve accumulation pressure****PLV accumulation pressure**

Pressure at which a PLV discharges the pump rated flow rate.

3.35**pressure-limiting valve set pressure****PLV set pressure**

Pressure at which a PLV starts to release pressure by discharging flow.

3.36**pressure-retaining part**

Any part whose mechanical failure would allow process or motive fluid to escape to the atmosphere.

3.37**pump efficiency**

Ratio of the pump's hydraulic power at discharge to its brake power input. Rated Pump efficiency is calculated at the rated point.

NOTE The hydraulic power is calculated significantly different in compressible (multiphase) fluids (see specific paragraphs on MPPs).

3.38**purchaser**

Agency that issues the order and specification to the vendor.

NOTE The purchaser may be the owner of the plant in which the equipment is to be installed or the owner's appointed agent.

3.39**rated operating point**

Point at which the vendor certifies that pump performance is within the tolerances stated in this standard.

NOTE Normally the rated operating point is the specified operating point with the highest flow.

3.40**rated power**

Power delivered to the pump input shaft at rated operating point. It is also called brake power (brake horsepower, brake kilowatts, etc.).

3.41**rated speed**

Highest rotational speed (revolutions per minute) required to meet any of the specified operating conditions.

NOTE Rated speed may not be the normal operating speed since the normal operating speed is determined by the normal operating point.

3.42

rotary pump

Positive displacement pump consisting of a casing containing gears, screws, lobes, cams, or vanes actuated by relative rotation between the drive shaft and the casing. There are no separate inlet and outlet valves. These pumps are characterized by their close running clearances.

3.43

settle-out pressure

Highest pressure the MPP will experience when not running and after equilibrium has been reached.

NOTE This may be a function of ambient temperature, PLV setting, and piping volume.

3.44

shutdown set point

Preset value of a measured parameter at which automatic or manual shutdown of the system or equipment is required.

3.45

slip

Quantity of fluid per unit of time that leaks through the internal clearances of a rotary pump. Slip depends on the internal clearances, the differential pressure, the characteristics of the fluid handled, and in some cases, the speed.

3.46

steady state

Condition under which specific metering parameters such as: flow rate, differential pressure, speed, GVF, suction pressure, discharge pressure, temperature, and fluid type are not changing by more than $\pm 10\%$ over a two-minute period.

3.47

TIR

total indicator reading

total indicated run-out

Difference between the maximum and minimum readings (of a dial indicator or similar device), monitoring a face or cylindrical surface during one complete revolution of the monitored surface.

NOTE For a cylindrical surface, the total indicated run-out implies an eccentricity equal to half the reading. For a flat face, the indicated run-out implies an out-of-square equal to the reading.

3.48

trip speed

Speed (revolutions per minute) at which the independent emergency overspeed device operates to shut down a variable speed prime mover. The trip speed of any alternating current electric motors, except variable frequency drives, is the speed corresponding to the synchronous speed of the motor at maximum supply frequency.

3.49

unit responsibility

Obligation for coordinating the technical aspects, delivery, and documentation of the equipment and all auxiliary systems included in the scope of the order.

3.50

vendor

Manufacturer or manufacturer's agent that supplies the equipment and is normally responsible for service support.

3.51**volumetric efficiency**

Ratio of the pump rated capacity to the total theoretical displacement per unit time.

NOTE Volumetric efficiency is normally expressed as a percentage.

3.52**witnessed**

A classification of inspection or test where the purchaser is notified of the timing of the inspection or test and a hold is placed on the inspection or test until the purchaser or the purchaser's representative is in attendance.

4 General**4.1 Unit Responsibility**

The vendor shall assume unit responsibility and shall assure that all sub-vendors comply with the requirements of this standard and all reference documents. The technical aspects to be considered by the vendor include, but are not limited to, such factors as the power requirements, speed, rotation, general arrangement, couplings, dynamics, lubrication, sealing system, certified material test reports, instrumentation, piping, conformance to specifications and testing of components.

4.2 Whether the application is a liquid or a multiphase service, if MPP design criteria are required by the service conditions or specified by the purchaser by use of the multiphase datasheets, all of the standard clauses will apply, except where noted or qualified otherwise in this standard.

NOTE The following listing identifies the paragraphs where unique MPP design and testing requirements are described—3.12, 3.20, 3.21, 6.1.14.3, 6.7.3.2, 6.8.1.3, 6.8.1.8, 6.8.2.2, 6.10.1, 6.11.2, 7.1.1.1.2, 7.3.5, 7.6.1, 7.8, 8.1.8, 8.3.8, and Annex G.

4.3 Pump Designations**4.3.1 General**

NOTE Pictures and modified descriptions are used with permission of the Hydraulic Institute.

The pumps described in this standard are classified and designated as shown in Table 1.

Table 1—Pump Classification Type Identification

Pump Type (by Pumping Element)		Type	Type Code
rotary pumps	vane	vane in rotor	VR
		vane in stator	VS
	lobe	single	LS
		multiple	LM
	gear	external gears (timed)	GET
		external gears (untimed)	GEU
		internal gears (with crescent)	GI
	screw	single	SS
		multiple timed	SMT
multiple untimed		SMU	

NOTE Typical flows and pressures for these types of pumps are shown in Figure 9 and Figure 10, which have been provided courtesy of the Hydraulic Institute.

4.3.2 Sliding Vane Pump

In vane pumps, as illustrated in Figure 1, as the vane or vanes are moved by a rotor, thereby drawing fluid into, and forcing it from the pump chamber. These pumps may be made with vanes in either the rotor or stator and with radial hydraulic forces on the rotor balanced or unbalanced.

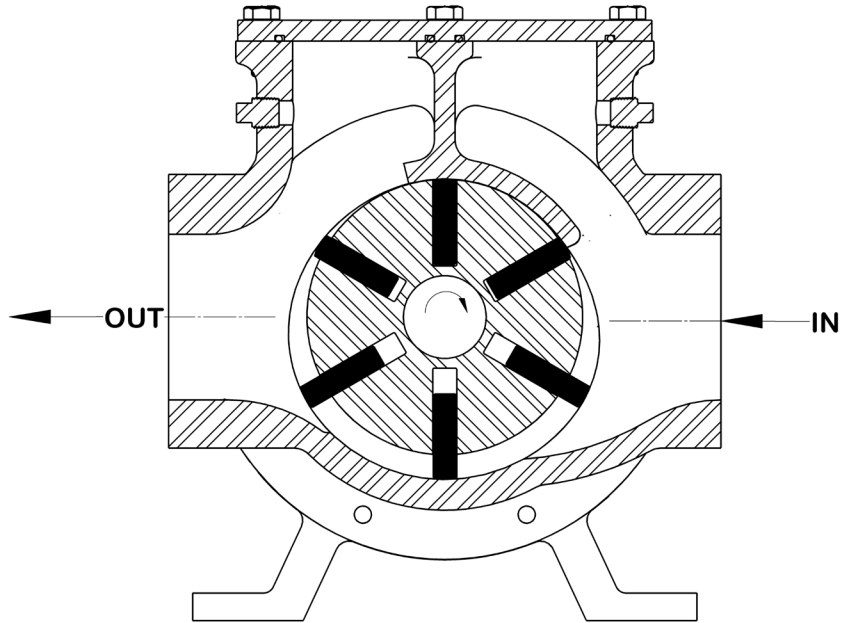

Figure 1—Sliding Vane Pump (Vane in Rotor)

4.3.3 Lobe Pump

In lobe pumps, as illustrated in Figure 2 and Figure 3, fluid is carried between rotor lobe surfaces and the pumping chamber from the inlet to the outlet. The rotor surfaces cooperate to provide continuous sealing. The rotors shall be timed by separate means. Each rotor has one or more lobes.

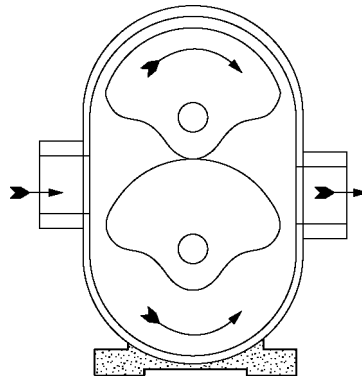

Figure 2—Single Lobe Pump

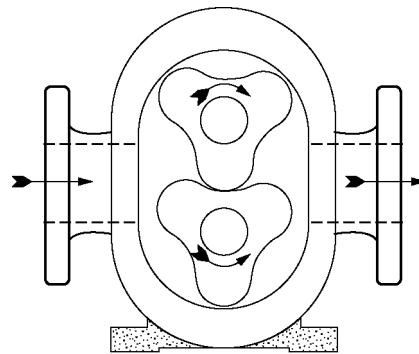

Figure 3—Three Lobe Pump

4.3.4 External Gear Pump

In gear pumps, as illustrated in Figure 4, fluid is carried between gear teeth and displaced when they mesh. The surfaces of the rotors cooperate to provide continuous sealing and either rotor is capable of driving the other. External gear pumps have all gear rotors cut externally. These may have spur, helical, or herringbone (double helical) gear teeth and may use timing gears.

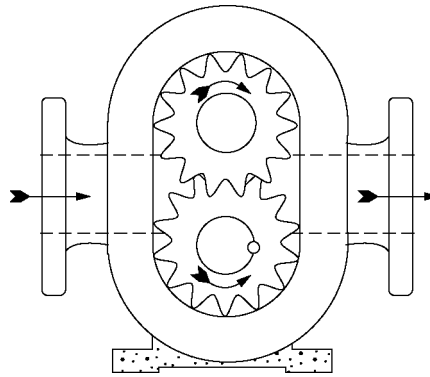

Figure 4—External Gear Pump

4.3.5 Internal Gear Pump (with Crescent)

Internal gear pumps have one rotor with internally cut gear teeth meshing with an externally cut gear. Pumps of this type are made with a crescent-shaped partition, as illustrated in Figure 5.

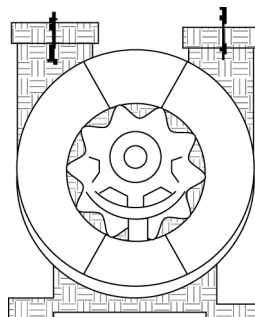

Figure 5—Internal Gear Pump

4.3.6 Progressing/Progressive Cavity Pump (PCP)

In screw pumps, fluid is carried in spaces formed by screw(s) and the screw housing and is displaced axially as they mesh.

Single screw pumps (progressing cavity pumps), illustrated in Figure 6, have a rotor with external threads and a stator with internal threads. The rotor threads are eccentric to the axis of rotation.

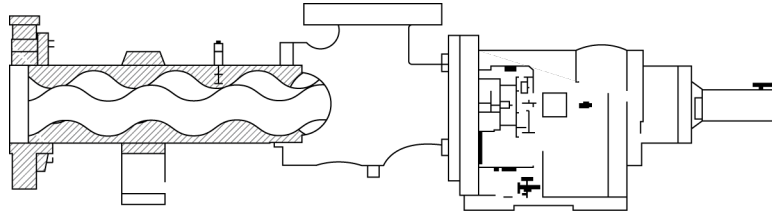

Figure 6—Progressing/Progressive Cavity Pump (PCP)

4.3.7 Multiple Screw Pump

Multiple screw pumps have multiple external screw threads. Such pumps, as those illustrated in Figure 7 and Figure 8, may be timed or untimed.

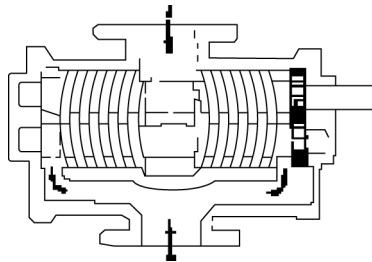

Figure 7—Twin Screw Pump (with Timed Gears)

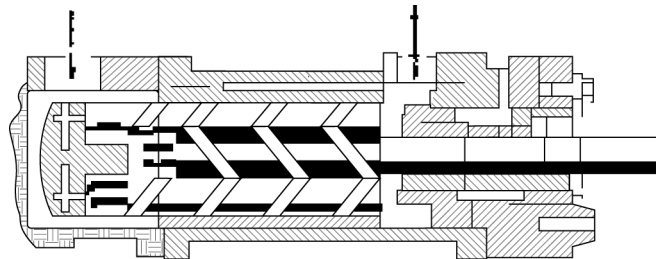

Figure 8—Three-screw Pump (with Untimed Gears)

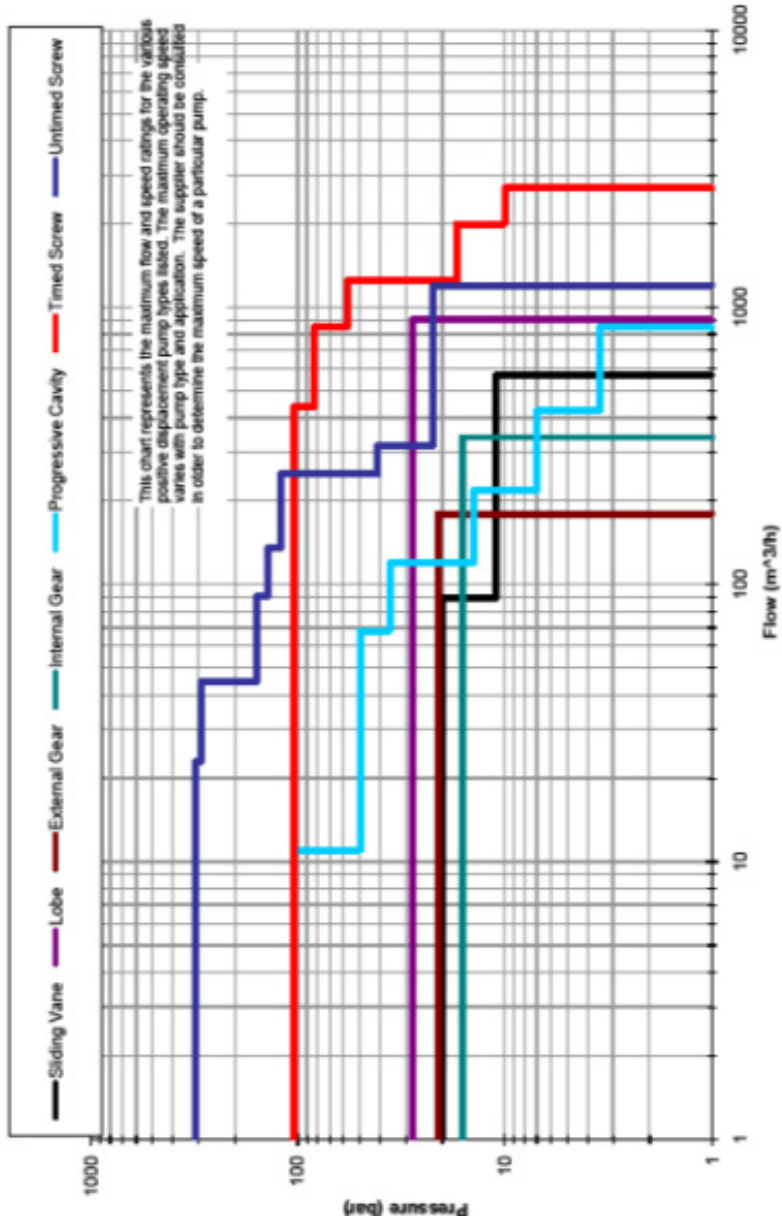

Figure 9—Rotary Pump Consolidated Range Chart (Typical Range in SI Units)

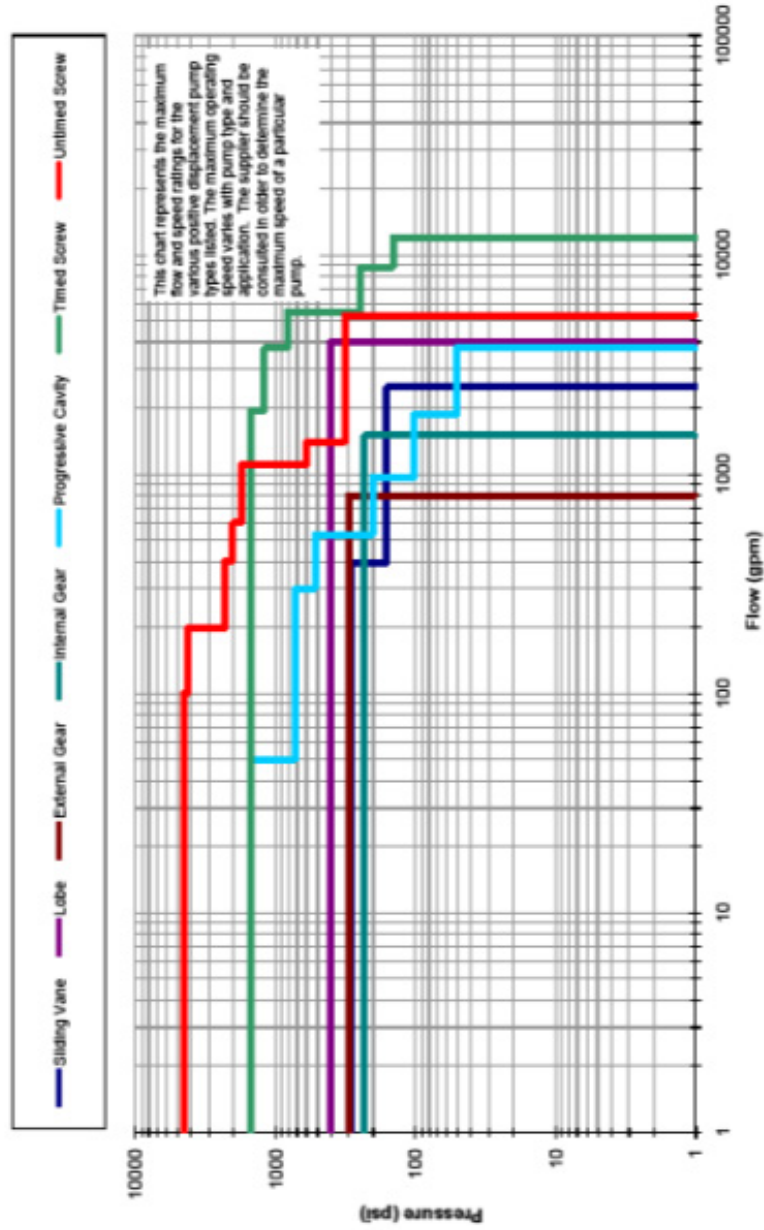

Figure 10—Rotary Pump Consolidated Range Chart (Typical Range in USC Units)

5.1 [●] Units of Measure

Drawings and maintenance dimensions of pumps shall be in SI units or U.S. customary (USC) units.

Purchaser's use of a USC data sheet (see Annex A.2) indicates the USC system of measurements shall be used for all data, drawings, and maintenance dimensions. Purchaser's use of an SI data sheet (see Annex A.1) indicates the SI system of measurements shall be used.

NOTE Dedicated Data Sheets for SI units and for U.S. customary units are provided in Annex A.

5.2 Statutory Requirements

The purchaser and the vendor shall determine the measures to be taken to comply with any governmental codes, regulations, ordinances, directives, or rules that are applicable to the equipment, its packaging, and any preservatives used.

5.3 Documentation Requirements

The hierarchy of documents shall be specified.

NOTE Typical documents include company and industry specifications, meeting notes, and modifications to these documents.

6 Basic Design

6.1 General

- [●] **6.1.1** The purchaser shall specify the period of uninterrupted continuous operation. Shutting down the equipment to perform required maintenance or inspection during the uninterrupted operation period is not acceptable.

6.1.1.1 If a range of operating conditions is specified, the pump vendor shall advise the purchaser about the pump's minimum and maximum capacity and normal operating point at its rated differential pressure and its required brake horsepower.

6.1.1.2 Anticipated process variations that may affect the sizing of the pump and the driver (such as changes in pressure, temperature, or properties of fluids handled, and special plant startup conditions) shall be specified.

NOTE 1 It is realized that there are some services where this objective is easily attainable and others where it is difficult.

NOTE 2 Auxiliary system design and design of the process in which the equipment is installed are very important in meeting this objective.

6.1.1.3 Only equipment that is field proven, as defined by the purchaser, is acceptable.

NOTE Purchasers can use their engineering judgment in determining what equipment is field proven. API 691 can provide guidance.

- [●] **6.1.1.4** If specified, the vendor shall provide the documentation to demonstrate that all equipment proposed qualifies as field proven.

6.1.1.5 In the event no such equipment is available, the vendor shall submit an explanation of how their proposed equipment can be considered field proven.

NOTE A possible explanation can be that all components comprising the assembled machine satisfy the field proven definition.

6.1.2 The vendor shall advise in the proposal of any components designed for a finite life.

NOTE It is recognized that these are design criteria.

- [•] **6.1.3** The purchaser shall specify if equipment will be supplied in accordance with API RP 691. If API RP 691 has been specified, the vendor shall identify all machinery components that have a TRL < 7 per API RP 691 Section 4.3.2 Table 1.
- [•] **6.1.4** Unless otherwise specified, pumps shall be designed for flammable or hazardous services.
 - 6.1.5** Control of the sound pressure level of all equipment supplied shall be a joint effort of the purchaser and the vendor having unit responsibility. The equipment provided by the vendor shall conform to the maximum allowable sound pressure level specified. To determine compliance, the vendor shall provide both maximum sound pressure and sound power level data per octave band for the equipment.
 - 6.1.6** Equipment shall be selected to run simultaneously at the pressure-limiting valve accumulation pressure and at trip speed without suffering damage. Vendor shall advise purchaser of increased power operating requirements necessary to achieve this.
 - 6.1.7** For direct-driven equipment, the equipment's maximum continuous allowable speed shall be not less than 105 % of the rated speed for adjustable speed machines and shall be equal to the synchronous speed for constant speed motor drives.
 - 6.1.8** For gear-driven equipment, the gear input shaft maximum continuous allowable speed shall not be less than 105 % of the rated speed for adjustable speed machines and shall be equal to the synchronous speed for constant speed motor drives.
 - 6.1.9** The equipment's trip speed shall not be less than the following percentages of maximum continuous allowable speed:
 - a) adjustable speed driver—110 %,
 - b) constant speed motor—100 %.
 - 6.1.10** The arrangement of the equipment, including piping and auxiliaries, shall be developed jointly by the purchaser and the vendor. The arrangement shall provide adequate clearance areas and safe access for operation and maintenance.
- [•] **6.1.11** Motors, electrical components, and electrical installations shall be suitable for the area classification (class, group, and division or zone) specified by the purchaser and shall meet the requirements of the applicable sections of IEC 60079, or NFPA 70, API RP 500, and NEC as specified, as well as any local codes specified and supplied by the purchaser.
 - 6.1.12** Oil reservoirs and housings that enclose moving lubricated parts such as bearings, shaft seals, highly polished parts, instruments, and control elements shall be designed to prevent contamination by moisture, dust, and other foreign matter during periods of operation and idleness.
 - 6.1.13** The arrangement of the equipment, including piping and auxiliaries, shall be developed jointly by the purchaser and the vendor. The arrangement shall provide adequate clearance areas and safe access for operation and maintenance.
 - 6.1.14** All equipment (machine, driver, and auxiliary equipment as specified) shall be designed to perform on the test stand and on its permanent foundation within the specified test tolerances (see 6.11 and 8.3.6).
 - 6.1.14.1** After installation, the performance of the combined units shall be the joint responsibility of the purchaser and the vendor who has unit responsibility.

6.1.14.2 Many factors can adversely affect performance of the pump at site. These factors include piping layout, piping connection loads, alignment at operating conditions, support structure, handling during shipment and handling and assembly on site.

- [●] **6.1.14.2.1** To minimize the influence of these factors, the vendor shall review and comment on the purchaser's piping and foundation drawings, when specified.

6.1.14.2.2 If specified, the vendor's representative shall witness:

- a) A check of the piping alignment performed by unfastening the major flanged connections of the equipment.
- b) The initial shaft alignment check at ambient conditions.
- c) Shaft alignment at operating temperature, (i.e. hot alignment check).

NOTE Refer to API RP 686 for basic guidelines for conducting piping alignments, shaft hot and cold alignments.

6.1.14.3 If specified, for MPPs, the vendor shall confirm that the unit is capable of start-up at settle-out and maximum suction pressure.

6.1.15 The equipment, including all auxiliaries, shall be suitable for operation under the environmental conditions specified. These conditions shall include whether the installation is indoors (heated or unheated) or outdoors (with or without a roof), maximum and minimum temperatures, sun metal temperature, unusual humidity, and dusty or corrosive conditions.

6.1.16 The equipment, including all auxiliaries shall be suitable for operation using the utility conditions specified.

6.1.17 Spare and replacement parts for the equipment and all furnished auxiliaries shall meet all the criteria of this standard.

6.1.18 Bolting

6.1.18.1 Bolting shall conform to 6.1.18.2 through 6.1.18.5.

6.1.18.2 Details of threading shall conform to ASME B1.1, ISO 261, ISO 262, ISO 724, and ISO 965.

6.1.18.3 Internal socket-type, slotted-nut, or spanner-type bolting shall not be used unless approved by the purchaser. This restriction does not apply to set-screws for mechanical seals.

NOTE 1 For limited space locations, integrally flanged fasteners can be supplied.

NOTE 2 A set-screw is a headless screw with an internal hexagonal opening in one end.

6.1.18.4 Fasteners (excluding washers and set-screws) shall have the material grade and vendor's identification symbols applied to one end of studs 10 mm (0.38 in.) in diameter and larger and to the heads of bolts 6 mm (0.25 in.) in diameter and larger. If the available area is inadequate, the grade symbol may be marked on one end and the vendor's identification symbol marked on the other end. Studs shall be marked on the exposed end.

6.1.18.5 Metric fine and UNF threads shall not be used.

6.1.19 Pump Mounting Surfaces

6.1.19.1 The pump mounting surfaces shall meet the following criteria.

6.1.19.2 They shall be fully machined to a finish of 6.3 μm (250 $\mu\text{in.}$) arithmetic average roughness (Ra) or smoother.

6.1.19.3 To prevent a soft foot, each individual mounting surface shall be machined with a flatness tolerance of 25 μm (0.001 in.).

6.1.19.4 The mounting surfaces shall be machined flat and parallel. Corresponding surfaces shall be in the same plane within 150 $\mu\text{m}/\text{m}$ (0.002 in./ft) of distance between the mounting surfaces.

NOTE Some users require 0.0005 in./ft not to exceed a maximum of 0.010 in.

6.1.19.5 The upper machined, or spot faced surface, shall be parallel to the mounting surface.

NOTE Typically, the spot-face is parallel ≤ 0.002 in.

6.1.19.6 Hold-down bolt holes shall be drilled perpendicular to the mounting surface or surfaces, machined or spot faced to a diameter three times that of the hole and to allow for equipment alignment. For hold-down bolts 25 mm (1 in.) and larger the hole shall be 13 mm (0.50 in.) larger in diameter than the hold-down bolt. For bolts less than 25 mm (1 in.) in diameter, the holes shall be 5 mm (0.25 in.) larger in diameter than the bolt.

NOTE Typically, perpendicularity ≤ 0.001 in. per inch of bolt hole bore.

6.2 Selection and Rating of Pump Type

The vendor shall recommend the pump speed for the specified service, considering such factors as net positive suction head available (NPIPA/NPSHA), net positive suction head required (NPIPR/NPSHR), maximum fluid viscosity, solids and abrasives content, and wear allowance if required.

NOTE Recognize that different rotary pump designs operate on different principles so that no one speed criterion can be applied.

6.3 Pressure-containing and Pressure-retaining Parts

6.3.1 The pressure-containing parts shall be designed in accordance with 6.3.1.1 (or 6.3.1.2, as selected by the vendor) and 6.3.1.3 to achieve the following:

- a) operate without leakage while subject simultaneously to the maximum allowable casing pressure (MACP) (and corresponding temperature) and the worst case combination of maximum allowable nozzle loads applied to all nozzles,
- b) withstand the hydrostatic test in 8.3.2.

6.3.1.1 Pressure-containing components may be designed with the aid of finite element analysis provided that the value of the stress intensity reflects a requirement to perform a hydrostatic test at 150 % of MACP.

6.3.1.2 The allowable tensile stress used in the design of the pressure components, excluding bolting, for any material shall not exceed 0.25 times the minimum ultimate tensile strength or 0.67 times the minimum yield strength for the material whichever is lower across the full range of specified operating temperature.

6.3.1.3 For casing joint bolting, the allowable stress, as determined in 6.3.1.2 shall be used to determine the total bolting area based on hydrostatic load and gasket preload, as applicable. The preload stress shall not exceed 0.75 times the bolting material minimum yield strength.

NOTE Preloading the bolting is required to prevent unloading the bolted joint due to cyclic operation.

6.3.1.4 A corrosion allowance of at least 3 mm (0.12 in.) shall be added to the casing thickness used in 6.3.1. The corrosion allowance shall also be added to all auxiliary connections exposed to the same fluid as the pressure-containing casing.

6.3.1.5 The vendor may propose alternative corrosion allowances for consideration if materials of construction with superior corrosion resistance are employed.

6.3.2 The purchaser shall install a pressure-limiting valve (PLV) for each positive displacement pump. The PLV accumulation pressure shall not exceed the maximum allowable working pressure (MAWP) of the pump.

6.3.3 Casing and other pressure-retaining parts and supports shall be designed to prevent detrimental distortion (e.g. reduced MTBF) caused by the worst combination of temperature, pressure, torque, and allowable external forces and moments based on the specified operating conditions.

6.3.3.1 Unless otherwise specified, the suction region and the discharge region of the pump shall be designed for different pressure ratings.

[●] **6.3.3.2** If specified, suction regions shall be designed for the same MACP as the discharge section.

6.3.3.3 Casings shall be sealed using flat gaskets; confined, controlled-compression spiral wound gaskets, or O-rings.

NOTE Information on controlled compression gaskets is found in ASME B16.20.

6.3.4 The use of threaded holes in pressure-retaining parts shall be minimized. To prevent leakage in these parts, metal equal in thickness to at least half the nominal bolt diameter (including the allowance for corrosion) shall be left around and below the bottom of drilled and threaded holes. The depth of the threaded holes shall be at least 1.5 times the stud diameter.

6.3.5 If required by the pump design, jackscrews, cylindrical alignment dowels or other appropriate devices shall be provided to facilitate disassembly. If jackscrews are used as a means of parting contacting faces, one of the faces shall be relieved (counter-bored or recessed) to prevent a leaking joint or an improper fit caused by marring of the face.

6.3.6 If jacketed pump casings are required, jacket passages shall not open into casing joints.

6.3.7 Jackets shall be designed for minimum of 5.2 bar (75 psi) working pressure and shall be suitable for hydrostatic testing at a minimum of 8 bar (115 psi).

6.4 Casing Connections

6.4.1 Provision shall be made for complete venting (unless it is self-venting) and draining of the pump and systems provided by the vendor.

6.4.2 All pumps shall be provided with vent and drain connections, except that vent connections may be omitted if the pump is made self-venting by the arrangement of the nozzles.

6.4.2.1 If specified, drain(s) and/or vent(s) shall be piped to the edge of the baseplate or mounting plate.

6.4.2.2 If the pump cannot be completely drained for geometrical reasons, this shall be stated in the proposal.

6.4.2.3 The operating manual shall include a drawing indicating the quantity and location(s) of the fluid remaining in the pump.

NOTE A pump is considered functionally self-venting if the nozzle arrangement and the casing configuration permit sufficient venting of gases to prevent loss of prime during the starting sequence.

6.4.3 Casing Opening Sizes

6.4.3.1 Openings for nozzles and other pressure casing connections shall be standard pipe sizes in accordance with ISO 6708 or ASME B16.5. Openings of DN 32, 65, 90, 125, 175, and 225 (NPS 1½, 2½, 3½, 5, 7, and 9) shall not be used.

6.4.3.2 Casing connections other than suction and discharge nozzles shall be at least DN 15 (NPS ½) for pumps with discharge nozzle openings DN 50 (NPS 2) and smaller. Connections shall be at least DN 20 (NPS ¾) for pumps with discharge nozzle openings DN 80 (NPS 3) and larger, except that connections for seal flush piping and gauges may be DN 15 (NPS ½) regardless of pump size.

6.4.4 Suction and Discharge Nozzles

6.4.4.1 Suction and discharge nozzles shall be flanged or machined and studded for sizes DN 50 (NPS 2) and larger. Sizes DN 40 (NPS 1½) and smaller may be threaded connections. When machined and studded suction and discharge nozzles are provided, the purchaser shall be provided nozzle details.

[•] **6.4.4.2** If specified, all connections shall be suitable for the MACP.

6.5 Auxiliary Connections

6.5.1 Connections welded to the casing shall meet the material requirements of the casing including impact values, rather than the requirements of the connected piping. All welding of connections, gussets, etc. shall be completed before the casing is hydrostatically tested (see 8.3.2).

[•] **6.5.2** If specified, piping shall be gusseted in two orthogonal planes to increase the rigidity of the piped connection.

6.5.2.1 Gussets shall be of a material compatible with the pressure casing and the piping and shall be made of flat bar with a minimum cross section of 25 mm to 3 mm (1 in. to 0.12 in.).

6.5.2.2 Gussets shall be located at or near the connection end of the piping and fitted to the closest convenient location on the casing to provide maximum rigidity. The long width of the bar shall be perpendicular to the pipe and shall be located to avoid interference with the flange bolting or any maintenance areas on the pump.

6.5.2.3 Gusset welding shall meet the fabrication requirements of 6.13.5, including post-weld heat treatment when required, and the inspection requirements of this standard (see 8.2.2).

6.5.2.4 Gussets may also be bolted to the casing if drilling and tapping is done prior to the hydrostatic test.

6.5.2.5 Piping may be clamped to gussets.

6.5.3 If recommended by the vendor and approved by the purchaser, threaded connections for pipe sizes exceeding DN 40 (NPS 1½) may be used.

NOTE For example:

- a) on nonweldable materials, such as cast iron;
- b) if essential for maintenance (disassembly and assembly); and
- c) where flanged or machined and studded openings are impractical.

6.5.3.1 Pipe nipples screwed or welded to the casing should not be more than 150 mm (6 in.) long and shall be a minimum of Schedule 160 seamless for sizes DN 25 (NPS 1) and smaller and a minimum of Schedule 80 for DN 40 (NPS 1½).

6.5.3.2 Nipples longer than 150 mm (6 in.) shall be gusseted.

6.5.3.3 The pipe nipple shall be provided with a welding-neck or socket-weld flange.

6.5.3.4 All auxiliary connections to the pressure casing, except seal gland, shall terminate in a flange meeting the requirements of 6.6.1.1 or 6.6.1.2. These connections shall be integrally flanged, socket welded or butt welded as specified by the purchaser. Seal welding of threaded connections is not permitted. Purchaser interface connections shall terminate in a flange.

[●] **6.5.3.5** If specified, special threaded fittings for transitioning from the casing to tubing for seal flush piping may be used provided a secondary sealing feature such as O-rings are used, and the joint does not depend on thread contact alone to seal fluid. The connection boss shall have a machined face suitable for sealing contact.

6.5.3.6 The nipple and flange materials shall meet the requirements of API 614.

6.5.3.7 Unless otherwise specified, pipe threads shall be tapered threads conforming to ASME B1.20.1. Openings and bosses for pipe threads shall conform to ASME B16.5.

NOTE For purposes of this provision, ISO 7-1 is equivalent to ASME B1.20.1.

[●] **6.5.4** If specified, cylindrical threads conforming to ISO 228-1 shall be used. If cylindrical threads are used, they shall be sealed with a contained face gasket, and the connection boss shall have a machined face suitable for gasket containment.

[●] **6.5.4.1** If specified, auxiliary connections to the pressure casing shall be machined and studded. These connections shall conform to the facing and drilling requirements of ASME B16.5 or ASME B16.1. Studs and nuts shall be furnished installed. The first 1½ threads at both ends of each stud shall be removed.

6.5.4.2 All connections shall be suitable for the hydrostatic test pressure of the region of the casing to which they are attached.

6.5.4.3 Threaded openings not connected to piping shall be plugged.

- a) Taper-threaded plugs shall be long-shank solid round-head, or long-shank hexagon-head bar stock plugs in accordance with ASME B16.11.
- b) If cylindrical threads are specified, plugs shall be solid hexagon-head plugs in accordance with DIN 910. These plugs shall meet the material requirements of the casing.
- c) A lubricant that is suitable for the contained fluid and for the service temperature shall be used on all threaded connections. Thread tape shall not be used. Plastic plugs shall not be used.

6.6 Flanges

[●] **6.6.1** Purchaser to specify whether ISO or ASME flanges are to be provided.

6.6.1.1 Gray cast iron flanges shall be flat-faced and, except as noted in 6.6.1.3, conform to the dimensional requirements of ISO 7005-2 and the flange finish requirements of ASME B16.1 or ASME B16.42. Nominal pressure (PN) 20 (Class 125) flanges shall have a minimum thickness equal to that of PN 40 (Class 250) flanges for sizes DN 200 (NPS 8) and smaller.

NOTE ISO 7005-2 (cast iron) flanges PN 20 and PN 50 are designed to be interchangeable with ASME B16.1 (gray cast iron) and B16.42 (ductile cast iron) but they are not identical. They are deemed to comply with dimensions specified in ASME B16.1 (gray cast iron) and B16.42 (ductile cast iron).

6.6.1.2 Flanges other than gray cast iron shall, as a minimum requirement, conform to the dimensional requirements of ISO 7005-1 PN 50 except as noted in 6.6.1.3 and the flange finish requirements of ASME B16.5 or ASME B16.47.

6.6.1.3 Flanges in all materials that are thicker or have a larger outside diameter than required by the relevant ISO (ASME) standards in this standard are acceptable. Nonstandard (oversized) flanges shall be identified as such and completely dimensioned on the arrangement drawing. If oversized flanges require studs or bolts of non-standard length, this requirement shall be identified as such on the arrangement drawing.

6.6.1.4 Flanges shall be full-faced or spot-faced on the back and shall be designed for through-bolting, except for jacketed casings.

6.6.1.5 The vendor shall provide mating flanges, studs, and nuts for non-standard connections.

6.6.1.6 Studs or bolt holes shall straddle center lines parallel to the main axes of the equipment.

6.6.1.7 All of the purchaser’s connections shall be accessible for disassembly without requiring the machine, or any major part of the machine, to be moved.

6.7 External Forces and Moments

6.7.1 The vendor shall specify, in the quotation, the magnitude of forces and moments which may be applied, simultaneously, to the inlet and outlet connections at the rated operating conditions. As a minimum, the pump inlet and outlet connections shall be capable of withstanding the limits indicated in Table 2.

Table 2—Nozzle Loadings

SI Units Nominal Size of Flange (DN)	Forces Each Nozzle F_x, F_y and F_z (N)	Moments Each Nozzle M_x, M_y and M_z (N•m)
≤50	650	350
80	1040	560
100	1300	700
150	1950	1050
200	2600	1400
250	3250	1750
300	3900	2100
350	4550	2450
400	5200	2800
500	6500	3500
600	7800	4200
USC Units Nominal Size of Flange (NPS)	Forces Each nozzle F_x, F_y and F_z (lbf)	Moments Each Nozzle M_x, M_y and M_z (ft-lbf)
≤2	150	250
3	225	375
4	300	500
6	450	750
8	600	1000
10	750	1250
12	900	1500
14	1050	1750

Table 2—Nozzle Loadings (Continued)

SI Units Nominal Size of Flange (DN)	Forces Each Nozzle F_x , F_y and F_z (N)	Moments Each Nozzle M_x , M_y and M_z (N•m)
16	1200	2000
20	1500	2500
24	1800	3000

6.7.2 For pumps with connection sizes not indicated in Table 2, the inlet and outlet nozzles shall be capable of withstanding forces and moments from external piping determined by the following formulas:

$$F_x = 13D \quad M_x = 7D$$

$$F_y = 13D \quad M_y = 7D$$

$$F_z = 13D \quad M_z = 7D$$

Or in conventional units:

$$F_x = 75D \quad M_x = 125D$$

$$F_y = 75D \quad M_y = 125D$$

$$F_z = 75D \quad M_z = 125D$$

where

D is the nominal pipe size (NPS) of the pump nozzle connection in millimeters (inches);

F_x is the force in Newtons (pounds) on the x-axis, which is parallel to the shaft axis;

F_y is the horizontal force in Newtons (pounds) on the y-axis, which is mutually perpendicular to the x- and z-axis;

F_z is the vertical force in Newtons (pounds) on the z-axis, which is mutually perpendicular to the y- and x-axes;

M_x is moment around the x-axis, in Newton-meters (pound-feet);

M_y is moment around the y-axis, in Newton-meters (pound-feet);

M_z is moment around the z-axis, in Newton-meters (pound-feet).

The vendor shall submit comparable criteria for pump casings constructed of other materials.

6.7.3 Casing Liners

[●] 6.7.3.1 If specified, replaceable liners shall be provided for screw pumps.

6.7.3.2 Unless otherwise specified for multiphase twin screw pumps, hard coatings or surface hardening shall be applied to the liner bores.

NOTE Hard-coated or surface-hardened liners are used to reduce the rate of degradation due to abrasives. See Annex B for additional information.

6.8 Rotating Elements

6.8.1 Rotors

6.8.1.1 Stationary and moving pumping elements shall be designed and fabricated of material to prevent galling. Rotating parts shall be properly aligned. Internal loads shall be fully supported by the use of such means as hydraulic balance, bearings, or bushings.

- [•] **6.8.1.2** If specified, for twin screw pumps, rotor stiffness shall be adequate to prevent contact between the rotor bodies and the casing and between gear-timed rotor bodies at the most unfavorable specified conditions.

6.8.1.3 For twin screw MPPs, the maximum allowable rotor deflection under the worst operating condition (consider temperature, MAWP, nozzle loads, particulate, etc. as specified on the datasheet) shall be calculated and able to be demonstrated through computer modeling to show noncontact between rotors and the surrounding pump casing.

- [•] **6.8.1.3.1** If specified, the purchaser shall be able to review these calculations.

6.8.1.3.2 The rotor deflection requirement does not apply to PCPs.

6.8.1.4 Rotor bodies not integral with the shaft shall be positively attached to the shaft to prevent relative motion under any condition. Structural welds on rotors shall be full-penetration continuous welds and shall be stress relieved with appropriate ASTM heat treatment procedure.

6.8.1.5 For multiple screw pumps, each rotor set shall be clearly marked with a unique identification number on each male and female rotor. This number shall be on the end of the shaft opposite the coupling or in an accessible area that is not prone to maintenance damage.

6.8.1.6 All shaft keyways shall have fillet radii conforming to ASME B17.1 or ISO 3117.

- [•] **6.8.1.7** If specified, hardened rotors shall be provided for screw pumps.

6.8.1.8 Unless otherwise specified for multiphase twin screw pumps, hard coatings or surface hardening shall be applied to the rotors.

NOTE Hard-coated or surface-hardened screws are used to reduce the rate of degradation due to abrasives (see Annex B for additional information).

6.8.1.9 Rotors for twin screw pumps shall be dynamically balanced to ISO 1940-1 Grade G2.5.

6.8.2 Timing Gears

6.8.2.1 Timing gears, when furnished, may be spur, helical, or herringbone (double helical) type. All gears shall be the coarse pitch type, and the gear quality shall be a minimum of 9 as defined by AGMA. The gears shall be designed in accordance with AGMA 2001/2101, DIN 3990 (or ISO 6336) with a minimum service factor of 1.5.

6.8.2.2 For twin screw MPPs, the timing gears shall be designed in accordance with AGMA 2001/2101, DIN 3990 (or ISO 6336) with a minimum service factor of 2.0. The timing gears shall be made of forged steel and shall be manufactured to a minimum gear quality level of 11 as defined by AGMA.

- [•] **6.8.2.3** If specified, the gear enclosing chamber shall not be subject to contact with the process fluid.

6.8.2.4 For external timing gears, inspection ports or other means shall be provided on the housing covers, such that timing gears may be inspected without disassembly of the unit.

6.9 Mechanical Shaft Seals

6.9.1 Cartridge mechanical shaft seals shall be furnished. If available for the pump(s) specified by the purchaser, API 682 compliant cartridges shall be supplied.

6.9.2 Seal selection shall be suitable for specified variations in suction and/or discharge conditions during start-up, operation, or shutdown, including possible upset conditions.

6.9.3 If the seal is exposed to suction pressure, special consideration is required for low suction pressure conditions or when a pump is subjected to an NPSH test requirement.

6.9.4 If the seal offered is not compliant with the purchaser specification or is not compliant with API 682, the following items shall be provided in the proposal:

- a) category,
- b) type,
- c) arrangement and geometry,
- d) materials of construction,
- e) reference list.

NOTE 1 Space or design parameters for some pump types, sizes, or applications make the use of API 682 seals impractical.

NOTE 2 seals that fall outside API 682 size range are classified as "engineered seals" but often meet all the typical API 682 requirements.

6.9.5 The design of the component parts shall be suitable for the specified service conditions and consistent with API 682. The purchaser shall specify the seal requirements using the selection process and the datasheets in API 682 for this purpose including any required seal flush plans as defined by API 682.

6.9.6 Single seals shall be equipped with a close-fitting throttle bushing on the atmospheric side of the seal to restrict the rate of leakage. If this is not possible due to space limitations, a suitable means of detecting and controlling the leakage shall be provided.

6.9.7 The seal shall be accessible for inspection and removal without disturbing the driver. Unless otherwise specified, a spacer coupling, with a spacer of the next standard length longer than the seal shall be provided by the vendor.

6.9.8 Seal chamber face run-out (TIR) shall not exceed 0.5 $\mu\text{m}/\text{mm}$ (0.0005 in./ in.) of seal chamber bore diameter.

6.9.9 If a seal gland is used, its component parts shall be satisfactory for the maximum seal-chamber design pressure and pumping temperature. It shall have sufficient rigidity to avoid any distortion that would impair seal operation, including distortion that may occur during tightening of the bolts or nuts.

6.9.10 The mating joint between the seal gland and the seal chamber face shall incorporate a confined gasket to prevent blowout.

6.9.10.1 The gasket shall be of the controlled compression type (O-ring or spiral-wound gasket) with metal to metal gland to seal-chamber contact.

6.9.10.2 If space or design parameters make this requirement impractical, an alternative seal gland design shall be submitted to the purchaser for approval.

6.9.11 Specified seal and pump connections shall be identified by symbols permanently marked on the component.

6.9.11.1 Symbols shall be in accordance with those specified in API 682.

6.9.11.2 If a seal gland utilizes a common design with multiple ports for symmetrical installation on multiple shaft pumps (right and left), the ports shall be appropriately identified.

6.9.12 Seal glands and seal chambers shall have provision for only those connections required by the seal flush plan. If other tapped connections are present but not used, they shall be plugged and labeled in accordance with API 682.

6.9.13 The seal chamber shall be provided with an internal or external vent to permit complete venting of the chamber before start-up.

6.9.14 If seal flushing and cooling is provided by the pumped fluid, the pump vendor shall ensure that sufficient flow reaches the primary seal faces to provide for cooling and maintenance of a stable film at the seal faces. Allowance for cooling flow shall be made when determining the pump capacity to meet delivered flow requirements.

6.9.15 If an external source of seal flushing is provided by the purchaser, the pump vendor shall specify the flow, pressure, temperature, and required lubricating properties of the flushing medium. If a restriction orifice is used, it shall not be less than 3 mm (0.12 in.) in diameter.

[•] **6.9.16** If specified, jackets shall be provided on seal chambers for heating. Heating requirements shall be agreed upon by the purchaser, pump vendor, and seal vendor.

6.9.17 If cooling is required, unless otherwise specified, air cooling shall be provided.

6.9.18 Mechanical seals shall be installed in the pump prior to shipment and shall be clean, lubricated, and ready for service. If seals require final adjustment or installation in the field, a metal tag shall be attached warning of this requirement.

[•] **6.9.19** If specified, in dual seal applications, the maximum seal leakage to atmosphere at the specified operating conditions, and the expected inner seal-oil leakage rates, if applicable, shall be provided.

NOTE This information is required to determine the rate of barrier or buffer seal oil usage and thus the sizing of the seal oil reservoir.

6.10 Bearings and Bearing Housings

6.10.1 Please provide title for this subsection

Rolling element bearing's basic rating life, L_{10h} , shall be at least 25,000 hours with continuous operation at rated conditions, and at least 16,000 hours at maximum radial and axial loads and rated speed. The basic rating, L_{10h} life, shall be calculated in accordance with ABMA 9 or ISO 281.

NOTE 1 The basic rating life, L_{10h} , is the number of hours, at the operating conditions, that 90 percent of a group of identical bearings, will complete or exceed before the evidence of failure.

NOTE 2 ABMA 9 or ISO 281 defines basic rating life L_{10} in units of millions of revolutions. Industry practice is to convert this to hours and refer to it as L_{10h} .

where

$$L_{10h} = (1,000,000/60N) L_{10}$$

N Revolutions per minute

NOTE 3 In twin screw MPPs, the bearings are sized and selected to manage the full radial load applied to the shaft, since hydrodynamic fluid film support between the rotor and liner is sometimes not available. Special attention needs also be given to minimum loading conditions to ensure that bearing skidding does not occur.

6.10.1.1 Roller bearings shall have the same L_{10h} life as ball bearings, but roller bearing life shall be calculated per ABMA 11.

6.10.1.2 These L_{10h} lives shall also apply for belt driven pumps.

6.10.2 Except for the angular contact type, ball bearings shall have a radial internal clearance (the total radial movement of the outer race with respect to the inner race in the plane perpendicular to the bearing axis) equivalent to ABMA Symbol 3, as defined in ABMA 20.

6.10.2.1 Tapered roller bearings shall have a radial internal clearance (Shaft OD to bearing inner race) equivalent to in ABMA 11.

6.10.2.2 Single or double-row bearings shall not be supplied with filling slots.

NOTE 1 Greater internal clearances may reduce the temperature rise of the lubricant. However, vibration velocities may be increased with greater clearances.

NOTE 2 For the purpose of this provision, ISO 5753-1 Group 3, is equivalent to ABMA 20 Group 3.

6.10.3 Housings for separately lubricated bearings shall be sealed against external contaminants. Such housings for oil-lubricated bearings shall contain a drain at the low point and shall be equipped with an oil-level gauge.

6.10.4 If re-greaseable type lubricated bearings are supplied, the vendor's design shall include a provision to protect against over greasing.

6.10.5 Rolling element bearings shall be located, retained, and mounted in accordance with the following.

6.10.5.1 Bearings shall be retained on the shaft with an interference fit and fitted into the housing with a diametral clearance, both in accordance with the recommendations of ABMA 7.

NOTE This paragraph applies to all rolling element bearings, including both ball and roller types. For certain roller bearings, such as cylindrical roller types with separable races, bearing housing diametral clearance may not be appropriate.

6.10.5.2 Bearings shall be mounted directly on the shaft. Bearing carriers are acceptable only with customer approval.

6.10.5.3 Bearings shall be located on the shaft using shoulders, collars, or other positive locating devices; snap rings and spring-type washers are not acceptable.

6.11 Vibration Limits

This clause does not cover piping vibration and pulsation. Refer to API RP 688.

6.11.1 Vibration Limits for Liquid Pumps

Measurement on Bearing Housing:

Steady state vibration at any speed: $V_u < 3.8$ mm/s RMS within operating range V_u on test or in the field: (0.15 in./s RMS)where

V_u is the unfiltered velocity;
RMS is the root mean squared.

6.11.2 Vibration Limits for Multiphase Pumps (MPPs)

Measurement on Bearing Housing:

For full liquid or any GVF on test: $V_u < 7.1$ mm/s RMS (0.28 in./s RMS)

Steady state vibration at any speed: $V_u < 5.5$ mm/s RMS within operating range in the field: (0.22 in./s RMS) where

V_u is the unfiltered velocity;
RMS is the root mean squared.

6.12 Lubrication

6.12.1 Lubrication for Rotary Pumps

6.12.2 If internal bearings or internal timing gears are used, the pump vendor shall verify that the pumped fluid will provide suitable lubrication.

6.12.3 Twin screw pumps shall be designed with splash lubricated bearings and bearing housings using mineral (hydrocarbon) oil.

6.12.4 Cooling, including an allowance for fouling, shall be provided to maintain oil and bearing life.

6.12.5 Based on the specified operating conditions and an ambient temperature of 43 °C (110 °F), oil lubrication temperatures shall be in accordance with 6.12.5.1 through 6.12.5.3.

6.12.5.1 For pressurized fluid film bearing systems, the bearing oil temperature rise shall not exceed 28 K (50 °F) above ambient temperature and if bearing metal temperature sensors are supplied, bearing metal temperatures shall not exceed 93 °C (200 °F).

6.12.5.2 During shop testing, and under the most adverse specified operating conditions, the bearing-oil temperature rise shall not exceed 28 K (50 °F).

6.12.5.3 For ring-oiled or splash systems, oil sump temperature shall be maintained below 82 °C (180 °F). During shop testing, the sump oil temperature rise shall not exceed 40 K (70 °F) and (if bearing temperature sensors are supplied) outer ring temperatures shall not exceed 93 °C (200 °F).

NOTE Pumps equipped with ring-oiled or splash lubrication systems might not reach temperature stabilization during shop tests of short duration.

6.12.6 Bearing lubrication may be splash, positive pressure, or gravity lubricated. A sight glass, gauge, or oil-level dipstick shall be provided.

6.12.7 Unless otherwise specified, pressurized oil systems shall conform to the requirements of API 614, Part 3—General Purpose Oil Systems.

- [•] **6.12.8** If specified, a pressure lubrication system shall be provided to supply oil at a suitable pressure and temperature to the pump, the driver, and any other driven equipment, including gears.
- [•] **6.12.9** If specified, the pressure lubrication system shall conform to the requirements of API 614, Part 2—Special Purpose Oil Systems.
- [•] **6.12.10** If grease lubricated rolling-element bearings are specified, lubrication shall be in accordance with 6.12.10.1 through 6.12.10.4.

6.12.10.1 Grease life (re-lubrication interval) shall be estimated using the method recommended by the bearing vendor or an alternative method approved by the purchaser.

6.12.10.2 Grease lubrication shall not be used if the estimated grease life is less than 2000 hours.

6.12.10.3 If the estimated grease life is 2000 hours or greater, but less than 25,000 hours, provision shall be made for re-greasing the bearings in service and for the effective discharge of old or excess grease, and the vendor shall advise the purchaser of the required re-greasing interval.

6.12.10.4 If the estimated grease life is 25,000 hours or more, grease nipples or any other system for the addition of grease in-service shall not be fitted.

6.13 Materials

6.13.1 Material Inspection of Pressure-containing Parts

6.13.1.1 The vendor is responsible for the review of the design limits of all materials and welds used in the equipment.

6.13.1.2 Defects that exceed the limits imposed in 6.13.3 and 6.13.4 shall be removed to meet the quality standards cited, as determined by additional magnetic particle or liquid penetrant inspection as applicable before repair welding.

NOTE See 8.2.2.1.1.

6.13.1.3 The purchaser shall be notified before making a major repair to a pressure containing part. Major repairs, for the purpose of purchaser notification only, is any defect that equals or exceeds any of the three criteria defined below:

- a) depth of the cavity prepared for repair welding exceeds 50 % of the component wall thickness;
- b) length of the cavity prepared for repair welding is longer than 150 mm (6 in.) in any direction;
- c) total area of all repairs to the part under repair exceeds 10 % of the surface area of the part.

6.13.1.4 All repairs to pressure containing parts shall be made as required by the following documents:

- a) the repair of plates, prior to fabrication, shall be performed in accordance with the ASTM standard to which the plate was purchased;
- b) the repair of castings or forgings shall be performed prior to final machining in accordance with the ASTM standard to which the casting or forging was purchased;
- c) the inspection of a repair of a fabricated casing or the defect in either a weld or the base metal of a cast or fabricated casing, uncovered during preliminary or final machining, shall be performed in accordance with 8.2.2.1.1.

6.13.2 Materials of Construction

[•] **6.13.2.1** Unless otherwise specified, the materials of construction of the pressure-containing casing shall be carbon steel as a minimum.

6.13.2.2 The materials shall be the vendor's standard for the operating conditions specified, except as required by the datasheet or this standard.

6.13.2.3 The materials of construction of all major components shall be clearly stated in the vendor's proposal.

- a) Materials shall be identified by reference to applicable international standards, including the material grade.
- b) If no such designation is available, the vendor's material specification, giving physical properties, chemical composition, and test requirements shall be included in the proposal.

- [•] **6.13.2.4** If specified, copper or copper alloys shall not be used for parts or machines or auxiliaries which are in contact with process fluids. Nickel-copper alloy (UNS NW 4400 or UNS N04400), bearing babbitt, and copper-containing precipitation-hardened stainless steels are excluded from this requirement.

NOTE Certain corrosive fluids in contact with copper alloys have been known to form explosive compounds.

6.13.2.5 The vendor's response to the inquiry shall specify the optional tests and inspection procedures that are necessary to ensure that materials are satisfactory for the service. Such tests and inspections shall be listed in the proposal.

NOTE The purchaser can specify additional optional tests and inspections, especially for materials used for critical components or in critical services.

6.13.2.6 External parts that are subject to rotary or sliding motions (such as control linkage joints and adjustment mechanisms) shall be of corrosion resistant materials suitable for the site environment.

6.13.2.7 Minor parts such as nuts, springs, washers, gaskets, and keys shall have corrosion resistance suitable for its environment.

- [•] **6.13.2.8** The purchaser shall specify any erosive or corrosive agents (including trace quantities) present in the process fluids and in the site environment, including constituents that may cause stress-corrosion cracking or attack elastomers.

NOTE Typical agents of concern are hydrogen sulfide, amines, chlorides, bromides, iodides, cyanides, fluorides, naphthenic acid and polythionic acid. Other agents affecting elastomer selection include ketones, ethylene oxide, sodium hydroxide, methanol, benzene, and solvents.

6.13.2.9 If austenitic stainless steel parts exposed to conditions that may promote inter-granular corrosion are to be fabricated, hard-faced, overlaid or repaired by welding, they shall be made of low-carbon or stabilized grades.

NOTE Overlays or hard surfaces that contain more than 0.10 % carbon can sensitize both low-carbon and stabilized grades of austenitic stainless steel unless a buffer layer that is not sensitive to inter-granular corrosion is applied.

- [•] **6.13.2.10** If specified, the vendor shall furnish material certificates that include chemical analysis and mechanical properties for the heats from which the material is supplied for pressure-containing castings, forgings, and shafts. Unless otherwise specified, piping nipples, auxiliary piping components, and bolting are excluded from this requirement.

6.13.2.11 If mating parts such as studs and nuts of austenitic stainless steel or materials with similar galling tendencies are used, they shall be lubricated with an anti-seizure compound of the proper temperature specification and compatible with the specified process liquid.

NOTE The torque loading values to achieve the necessary preload are likely to vary considerably depending upon whether or not an anti-seizure compound is used.

- [•] **6.13.2.12** The purchaser shall specify the amount of wet H₂S that may be present, considering normal operation, start-up, shutdown, idle standby, upsets, or unusual operating conditions such as catalyst regeneration.

NOTE In many applications, small amounts of wet H₂S are sufficient to require materials resistant to sulfide stress-corrosion cracking. If there are trace quantities of wet H₂S known to be present, or if there is any uncertainty about the amount of wet H₂S that may be present, the purchaser should consider specifying that reduced hardness materials are required.

[●] **6.13.2.13** The purchaser shall specify if reduced hardness materials are required.

6.13.2.13.1 If reduced hardness materials are specified in 6.13.2.13, they shall be supplied in accordance with NACE MR 0103 or MR 0175 (ISO 15156).

NOTE 1 NACE MR 0103 applies to oil refineries, LNG plants and chemical plants. NACE MR 0103 applies to materials potentially subject to sulfide stress corrosion cracking.

NOTE 2 NACE MR 0175 applies to oil and gas production facilities and natural gas sweetening plants. NACE MR 0175 applies to materials potentially subject to sulfide stress corrosion cracking. NACE MR 0175 is equivalent to ISO 15156.

6.13.2.13.2 If reduced hardness materials are specified, ferrous material not covered by NACE MR 0103 or NACE MR 0175 (ISO 15156) shall have a yield strength not exceeding 620 N/mm² (90,000 psi) and a hardness not exceeding HRC 22. Components that are fabricated by welding shall be post-weld heat treated, if required, so that both the welds and heat-affected zones meet the yield strength and hardness requirements.

6.13.2.13.3 If reduced hardness materials are specified, the following components shall have reduced hardness:

- a) the pressure casing,
- b) shafting (including wetted shaft nuts),
- c) pressure-retaining mechanical seal components (excluding seal faces),
- d) wetted bolting.

6.13.2.14 The vendor shall select materials to avoid conditions that may result in electrolytic corrosion. If such conditions cannot be avoided, the purchaser and the vendor shall agree on the material selection and any other precautions necessary.

NOTE If dissimilar materials with significantly different electrical potentials are placed in contact in the presence of an electrolytic solution, galvanic couples may be created that can result in serious corrosion of the less noble material. The NACE *Corrosion Engineer's Reference Book* is one resource for selection of suitable materials in these situations.

6.13.2.15 Steel made to a coarse austenitic grain size practice (such as ASTM A515) shall not be used. Only fully killed or normalized steels made to fine grain practice shall be used.

6.13.2.16 The vendor's data report forms, as specified in codes such as ASME *BPVC* Section VIII, are not required.

NOTE For impact requirements refer to 6.13.6.4 and 6.13.6.5.

[●] **6.13.2.17** The material specification of all gaskets and O-rings exposed to the pumped fluid shall be identified in the proposal.

- a) O-rings shall be selected, and their application limited, in accordance with API 682.
- b) O-ring materials shall be compatible with all specified services.
- c) It shall be specified on the datasheet if the service is such that there is a risk of rapid depressurization.
- d) Special consideration shall be given to the selection of O-rings for high-pressure services to ensure that they will not be damaged upon rapid depressurization (explosive decompression).

NOTE Susceptibility to explosive decompression depends on the gas to which the O-ring is exposed, the compounding of the elastomer, temperature of exposure, the rate of decompression, and the number of cycles.

6.13.2.18 The minimum quality bolting material for pressure-retaining parts shall be carbon steel (such as ASTM A307, Grade B) for cast iron casings, and high temperature alloy steel (such as ASTM A193, Grade B7) for steel casings. Carbon steel nuts (such as ASTM A194, Grade 2H) shall be used, except that case hardened carbon steel nuts (such as ASTM A563, Grade A) shall be used where space is limited. For alloy steel pressure retaining parts, the minimum bolting materials shall be 316/316L austenitic stainless steel. For temperatures below -29°C (-20°F), low-temperature bolting material (such as ASTM A320) shall be used.

6.13.3 Castings

6.13.3.1 Castings shall be sound and free from porosity, hot tears, shrink holes, blow holes, cracks, scale, blisters, and similar injurious defects in excess of that specified in the material specification or any additional specified acceptance criteria (see 8.2.2).

6.13.3.2 Surfaces of castings shall be cleaned by sandblasting, shot-blasting, chemical cleaning, or other standard methods to meet the visual requirements of MSS SP-55. Mold-parting fins and the remains of gates and risers shall be chipped, filed, or ground flush.

6.13.3.3 The use of chaplets in pressure castings shall be held to a minimum. If chaplets are necessary, they shall be clean and corrosion free (plating is permitted) and of a composition compatible with the casting.

6.13.3.4 Ferrous pressure-containing castings shall not be repaired by welding, peening, plugging, burning in, or impregnating, except as follows.

- a) Weldable grades of steel castings may be repaired by welding in accordance with 6.13.5. Weld repairs shall be inspected according to the same quality standard used to inspect the casting.
- b) All other repairs shall be subject to the purchaser's approval.

6.13.3.5 Fully enclosed cored voids, which become fully enclosed by methods such as plugging, welding, or assembly, are prohibited.

- [•] **6.13.3.6** If specified, for casting repairs made in the vendor's shop, repair procedures including weld maps, shall be submitted for purchaser's approval. The purchaser shall specify if approval is required before proceeding with repair. Repairs made at the foundry level shall be controlled by the casting material specification ("producing specification").

6.13.3.7 Pressure-retaining castings of carbon steel shall be furnished in the normalized and tempered condition.

6.13.4 Forgings

Pressure-containing ferrous forgings shall not be repaired except as stated below.

6.13.4.1 Weldable grade of steel forgings may be repaired by welding in accordance with 6.13.5. After major weld repairs, and before hydrostatic test, the complete forging shall be given a post-weld heat treatment to ensure stress relief and continuity of mechanical properties of both weld and parent metal.

6.13.4.2 All repairs that are not covered by the material specification shall be subject to the purchaser's approval.

6.13.5 Welding

- [•] **6.13.5.1** Welding and weld repairs shall be performed in accordance with Table 3. If specified, alternative standards may be proposed by the vendor for the purchaser's approval and, if so, they shall be referenced in the datasheets (see Annex A).

Table 3—Welding Requirements

Requirement	Applicable Code or Standard
welder/operator qualification	ASME <i>BPVC</i> Section IX or ISO 9606
welding procedure qualification	applicable material specification or, where weld procedures are not covered by the material specification ASME <i>BPVC</i> Section IX or ISO 15609/ISO 15614
non-pressure-retaining structural welding such as mounting plates or supports	AWS D1.1
magnetic particle or liquid penetrant examination of the plate edges	ASME <i>BPVC</i> Section VIII, Division 1, UG-93(d)(34)
post-weld heat treatment	applicable material specification or ASME <i>BPVC</i> Section VIII, Division 1, UW 40

6.13.5.2 Repairs and repair welds shall be reviewed and tested according to the following:

- a) The vendor shall be responsible for the review of all repairs and repair welds to ensure that they are properly heat treated and nondestructively examined for soundness and compliance with the applicable qualified procedures (Table 3).
- b) Repair welds shall be nondestructively tested by the same method used to detect the original flaw, however, the minimum level of inspection after the repair shall be by the magnetic particle method in accordance with 8.2.2.1 for magnetic material and by the liquid penetrant method for nonmagnetic material.
- c) Procedures for major repairs shall be subject to review by the purchaser before any repair is made.

6.13.5.3 Pressure-containing parts made of wrought materials or combinations of wrought and cast materials shall conform to the conditions specified in Items a) through d) below. These requirements do not apply to casing nozzles and auxiliary connections; see 6.13.5.4.

- a) Accessible surfaces of welds shall be inspected by magnetic particle or liquid penetrant examination after back chipping or gouging and again after post-weld heat treatment or, for austenitic stainless steels, after solution annealing.
- b) Pressure-containing welds, including welds of the casing to axial-joint and radial-joint flanges, shall be full-penetration welds.
- c) If dimensional stability of such casing component shall be assured for the integrity of pump operation, then post weld heat treatment shall be performed regardless of thickness.
- d) Plate edges shall be inspected by magnetic particle or liquid penetrant examination as required by internationally recognized standards such as Section VIII, Division 1, UG-93 (d)(3), of the ASME Code.

6.13.5.4 Connections welded to casings shall be installed as follows:

- a) Attachment of suction and discharge nozzles shall be by means of full-fusion, full-penetration butt welds.
 - i. Weld neck flanges shall be used for pumps handling flammable or hazardous liquids.
 - [●] ii. Socket weld flanges are acceptable if approved by the purchaser.
 - iii) Welding of dissimilar metals shall not be performed.
- b) If specified, proposed connection designs shall be submitted for purchaser approval before fabrication. The drawings shall show weld designs, size, materials, and pre and post-weld heat treatments.

- c) Post-weld heat treatment, if required, shall be performed after all welds, including piping welds, have been completed.
- d) Unless otherwise specified, auxiliary piping welded to alloy steel casings shall be of a material with the same nominal properties as the casing material.

6.13.6 Low-temperature Service

- [•] **6.13.6.1** The purchaser shall specify the minimum temperature and concurrent pressure including any transient operation. Vendor shall establish the minimum design metal temperature, impact test and other material requirements based on the information supplied by the purchaser.

NOTE Normally, this will be the lower of the minimum surrounding ambient temperature or minimum fluid pumping temperature; however, the purchaser can specify a minimum design metal temperature based on properties of the pumped fluid, such as auto-refrigeration at reduced pressures.

6.13.6.2 To avoid brittle failures, materials and construction for low temperature service shall be suitable for the minimum design metal temperature. The purchaser and the vendor shall agree upon the minimum design metal temperature and any special precautions necessary with regard to conditions that may occur during operation, maintenance, transportation, erection, commissioning, and testing.

NOTE 1 Selection of fabrication methods, welding procedures, and materials for vendor furnished steel pressure retaining parts is important for materials subject to temperatures below the ductile-brittle transition temperature.

NOTE 2 Some standards do not differentiate between rimmed, semi-killed, fully killed, hot-rolled, and normalized material, nor do they take into account whether materials were produced under fine- or course-grain practices all of which can affect material ductility.

- [•] **6.13.6.3** The purchaser shall specify whether ASME *BPVC* Section VIII, Division 1, shall apply with regard to impact-testing requirements.

- [•] **6.13.6.4** If ASME *BPVC* Section VIII, Division 1, is specified (see 6.13.6.3), the following shall apply:

- a) All pressure-retaining steels applied at a specified minimum design metal temperature below $-29\text{ }^{\circ}\text{C}$ ($-20\text{ }^{\circ}\text{F}$) shall have a Charpy V-notch impact test of the base metal and the weld joint unless they are exempt in accordance with ASME *BPVC* Section VIII, Division 1, UHA-51;
- b) Carbon steel and low alloy steel pressure-retaining parts applied at a specified minimum design metal temperature below $-29\text{ }^{\circ}\text{C}$ ($-20\text{ }^{\circ}\text{F}$) shall require impact testing as stated below.
 - 1) Impact testing is not required for parts with a governing thickness of 25 mm (1 in.) or less.
 - 2) Impact testing exemptions for parts with a governing thickness greater than 25 mm (1 in.) shall be established in accordance with Paragraph UCS-66 in ASME *BPVC* Section VIII, Division 1. Minimum design metal temperature without impact testing may be reduced as shown in Figure UCS-66.1. If the material is not exempt, Charpy V-notch impact test results shall meet the minimum impact energy requirements of Paragraph UG-84 of the ASME Code.

6.13.6.6 Governing thickness used to determine impact testing requirements shall be the greater of the following:

- a) The nominal thickness of the largest butt-welded joint.
- b) The largest nominal section for pressure containment, excluding:
 - 1) Structural support sections such as feet or lugs;
 - 2) Sections with increased thickness required for rigidity to mitigate deflection;

- 3) Structural sections required for attachment or inclusion of mechanical features such as jackets or seal chambers.
- c) One fourth of the nominal flange thickness, (in recognition that the predominant flange stress is not a membrane stress).

6.14 Nameplates and Rotation Arrows

6.14.1 A nameplate shall be securely attached at a readily visible location on the equipment and on any other major piece of auxiliary equipment.

6.14.2 Rotation arrows shall be cast in or attached to each major item of rotating equipment in a readily visible location.

6.14.3 Nameplates and rotation arrows (if attached) shall be of ANSI Standard Type 300 stainless steel or of nickel-copper alloy (Monel^{®13} or its equivalent). Attachment pins shall be of the same material. Welding is not permitted.

6.14.4 The following data (where relevant) shall be clearly stamped or engraved on the nameplate, in units consistent with the data sheet:

6.14.4.1 the purchaser's item number,

6.14.4.2 the vendor's name,

6.14.4.3 the machine's serial number,

6.14.4.4 the machine's size and type,

6.14.4.5 minimum and maximum allowable design limits,

6.14.4.6 rating data (including pressures, temperatures, speeds, and power),

6.14.4.7 MAWP(s),

6.14.4.8 hydrostatic test pressures,

6.14.4.9 critical speed(s).

7 Accessories

7.1 Drivers

7.1.1 General

[●] **7.1.1.1** The type of driver shall be specified.

7.1.1.1.1 The driver shall be designed and sized to meet all the specified operating conditions, including external gear and coupling losses, shall be in accordance with applicable specifications, as stated in the inquiry and order.

7.1.1.1.2 The driver shall be sized for satisfactory operation under the utility and site conditions specified.

a) Electric motors shall be constant torque. For engine drivers, which are never constant torque, the torque provided shall be in accordance with 7.1.1.1.

¹³ This term is used as an example only and does not constitute an endorsement of this product by API.

- b) For multiphase fluids, often the maximum driver requirement can be on 100 % liquid service. The purchaser shall inform the vendor if slug flow or other special conditions because these conditions could affect the maximum driver requirement.

7.1.1.2 The driver shall be sized to meet all process variations such as changes in the pressure, temperature, or properties of the fluid handled, and conditions specified in the inquiry, including plant start-up conditions.

7.1.1.3 The driver shall be capable of starting under the conditions specified and the starting method shall be agreed by the purchaser and the vendor. The driver's starting-torque capabilities shall exceed the speed-torque requirements of the driven equipment by a minimum of 10 %.

7.1.1.4 The supporting feet of drivers with a weight greater than 225 kg (500 lb.) shall be provided with vertical jackscrews.

7.1.2 Motors

7.1.2.1 Motor drives shall conform to internationally recognized standards such as API 541, API 546, or API 547 as applicable. Motors that are below the power scope of API 541, API 546, or API 547 shall be in accordance with IEEE 841. For applications that use an adjustable speed drive, coordination between the pump, motor, and adjustable speed drive vendors may be required. The motor rating shall be at least 110 % of the greatest power required (including gear and coupling losses) for any of the specified operating conditions. The motor nameplate rating, including service factor, shall be suitable for operation at 100 % of the PLV accumulation pressure. Consideration shall be given to the starting conditions of both the driver and driven equipment and the possibility that these conditions may be different from the normal operating conditions. Equipment driven by induction motors shall be rated at the actual motor speed for the rated load conditions.

NOTE 1 The 110 % applies to the design phase of a project. After testing, this margin is sometimes not available due to performance tolerances of the driven equipment.

NOTE 2 Electric motor drivers in accordance with IEEE 841 have a standard service factor of 1.0 for constant speed services. Motors in accordance with API 541, API 546, and API 547 have a standard service factor of 1.0. Some users of these motors prefer to use a 1.15 service factor.

NOTE 3 If possible, the electrical adjustable speed drive and motor are purchased from the same vendor.

- [•] **7.1.2.2** The purchaser shall specify the type of motor and its characteristics and accessories, including but not limited to the following:

- a) electrical characteristics;
- b) starting conditions (including the expected voltage drop on starting);
- c) type of enclosure;
- d) electrically insulated bearings, if required;
- e) sound pressure level;
- f) area classification, based on API 500 or equivalent international standard;
- g) class of winding insulation;
- h) required service factor;
- i) ambient temperature and elevation above sea level;
- j) transmission losses, if any;

- k) temperature detectors, vibration sensors, and heaters, if any;
- l) auxiliaries (such as motor-generator sets, ventilation blowers, and instrumentation);
- m) vibration acceptance criteria;
- n) use in adjustable speed drive applications.

7.1.2.3 Unless otherwise specified, the motor's starting torque shall accelerate the pump to rated speed at a voltage of 80 % of the nominal voltage.

7.1.2.4 Motors for belt drives shall be of extended-shaft construction and shall be suitable for the side loads imposed by the drive, considering the width of the bushing.

7.1.3 Steam Turbines

7.1.3.1 Steam turbine drivers shall conform to API 611.

7.1.3.1.1 Steam turbine drivers shall be sized to deliver continuously not less than 110 % of the maximum power requirement of the driven equipment, (including all gear and coupling losses), when operating at any of the specified operating conditions, with the specified normal steam conditions.

7.1.3.1.2 The maximum power requirement includes operation at 100 % of the PLV accumulation pressure.

NOTE The 110 % applies to the design phase of the project. After testing, this margin might not be available due to performance tolerances of the driven equipment.

7.1.4 Gear Units

7.1.4.1 Gear units integral with motor drivers are acceptable only if the driver nameplate rating is 18 kW (25 hp) or less. These integral gear units shall conform to AGMA 6091.

[•] **7.1.4.2** Coupled gears shall be either single helical or double helical type and shall conform to API 677. If specified, gear units shall conform to API 613.

7.1.4.3 The gear service factor shall be mutually agreed upon by both the gear and pump vendors for given service conditions such as torsional critical speeds. The gear service factor shall be subject to approval by the purchaser. In no case shall the service factor be less than the gear tooth factor required by the latest editions of AGMA 6013 for standard gear reducers or API 613 or API 677 as specified.

7.2 Couplings and Guards

7.2.1 Unless otherwise specified, flexible couplings and guards between drivers and driven equipment shall be supplied by the vendor of the driven equipment.

7.2.2 Unless otherwise specified, all-metal-flexible element, spacer-type couplings manufactured to meet AGMA 9000 class 9 shall be provided. Additionally, couplings shall comply with the items below.

- a) Flexible elements shall be of corrosion-resistant material.
- b) Couplings shall be designed to retain the spacer if a flexible element ruptures.
- c) Coupling hubs shall be steel.
- d) The distance between the pump and driver shaft ends (distance between shaft ends, or DBSE) shall be at least 125 mm (5 in.) and shall permit removal of the coupling, bearings, and seal, as applicable, without disturbing the driver, driver coupling hub or the suction and discharge piping.

- 1) This dimension, DBSE, shall always be greater than the minimum total seal length.
 - 2) The DBSE dimension usually corresponds to the nominal coupling spacer length.
- e) The maximum shaft thermal growth shall not exceed the allowable disc pack compression to avoid transmitting thrust loads to the pump and driver bearings.
 - f) Provision shall be made for the attachment of alignment equipment without the need to remove the spacer or dismantle the coupling in any way.

NOTE One way of achieving this is to provide at least 25 mm (1 in.) of bare shaft between the coupling hub and the bearing housing where alignment brackets may be located.

[•] **7.2.3** If specified, couplings shall be balanced to AGMA 9000 class 10.

[•] **7.2.4** If specified, couplings shall meet the requirements of API 671 or ISO 14691.

[•] **7.2.5** If specified, electrically insulated couplings shall be provided.

7.2.6 Information on shafts, keyway dimensions (if any), and shaft end movements due to end play and thermal effects shall be furnished to the vendor providing the coupling.

7.2.7 Flexible couplings shall be keyed to the shaft. Keys, keyways, and fits shall conform to AGMA 9002, "Commercial Class." Shaft coupling keyways shall be cut to accommodate a rectangular cross section key. Keys shall be fabricated and fitted to minimize unbalance.

7.2.8 Couplings and coupling to shaft junctures shall be rated for at least the maximum driver power, including the driver service factor.

7.2.9 For shaft diameters greater than 60 mm (2.375 in.) and if it is necessary to remove the coupling hub to service the mechanical seal, the hub shall be mounted with a taper fit and capable of transmitting the maximum torque.

7.2.9.1 The coupling fit taper shall be 1 in 16 [60 mm/m (0.75 in./ft), diametral]. Other mounting methods and tapers shall be agreed upon by the purchaser and the vendor.

7.2.9.2 Appropriate assembly and maintenance procedures should be used to assure that taper fit couplings have an interference fit.

7.2.10 Coupling hubs with cylindrical bores may be supplied with slip fits to the shaft and set-screws that bear on the key. Slip fits on cylindrical bores allow adjustment of the coupling axial position in the field without application of heat.

7.2.11 Coupling hubs designed for interference fits to the shaft shall be furnished with tapped puller holes at least 10 mm (0.375 in.) in diameter to aid in removal.

[•] **7.2.12** If specified, coupling hubs shall be fitted hydraulically.

7.2.13 If the driven-equipment vendor is not required to mount the driver, the coupling purchaser shall deliver the fully machined half-coupling to the driver vendor's plant or any other designated location, together with the necessary instructions for mounting the half-coupling on the driver shaft.

7.2.14 If the driver is a horizontal sleeve-bearing motor, limited end-float couplings shall be supplied to prevent end contact between shoulders on the motor shaft and its bearings.

7.2.15 Each coupling shall have a guard, which is removable without disturbing the coupled elements and shall meet the requirements below.

- a) Guards shall enclose the moving elements and the shafts to prevent personnel from contacting moving parts during operation of the equipment train. Allowable access dimensions shall comply with specified standards, such as ISO 14120 or EN 953.
- b) Guards shall be constructed with sufficient rigidity to withstand a 900 N (200 lbf) static point load in any direction without the guard contacting moving parts.
- [●] c) Guards shall be fabricated from either solid sheet or plate with no openings or expanded metal or perforated sheets if the size of the openings does not exceed 10 mm (0.375 in.).
 - i. Guards shall be constructed of steel, brass or nonmetallic (polymer) materials.
 - ii. Guards of woven wire shall not be used. If specified, non-sparking guards of agreed material shall be supplied.

7.3 Belt Drives

7.3.1 Belt drives shall only be used for equipment of 37 kW (50 hp) or less. Banded multi-V belts shall be provided.

7.3.1.1 If more than one banded multi-V belt is required, the vendor shall provide matched belt lengths.

7.3.1.2 All belts shall be of the static-conducting type and shall be oil resistant.

7.3.1.3 The drive service factor shall be in accordance with the service factor recommended

- [●] **7.3.1.4** If specified, a cog-belt type drive shall be provided. Details shall be mutually agreed upon between the vendor and the purchaser.

7.3.2 The vendor shall provide a positive belt-tensioning device. This device shall incorporate either a lateral adjustable base with guides and hold-down bolts, two belt-tensioning screws, and locking devices, or a vertical adjustable base with four belt-tensioning screws, each with a locking device. The belt-tensioning device adjustment range shall be sufficient to remove and replace belts without prying or forcing the belts off the sheaves and without moving the driver.

7.3.3 Belt drives shall meet the following requirements:

- a) the distance between the centers of the sheaves shall be at least 1.5 times the diameter of the larger sheave;
- b) the belt wrap (contact) angle on the smaller sheave shall be at least 140 degrees;
- c) the shaft length on which the sheave hub is fitted shall be at least equal to the width of the sheave hub;
- d) the length of a shaft key used to mount a sheave shall be equal to the length of the sheave bore;
- e) unless otherwise agreed or specified, each sheave shall be mounted on a tapered adapter bushing;
- f) to reduce the moment on shafts due to belt tension, the sheave overhang distance from the adjacent bearing shall be minimized;
- g) sheaves shall meet the balance requirements of ISO 1940-1 or ASA S2.19, Grade 6.3.

7.3.4 For exposed belts, guards meeting the requirements of 7.2.15 shall be provided by the vendor.

7.3.5 MPPs shall be direct driven. The use of drive belts is not permissible.

7.4 Baseplates

- [•] **7.4.1** If a baseplate is specified, the purchaser shall indicate the major equipment to be mounted on it. A baseplate shall be a single fabricated steel unit, unless the purchaser and the vendor mutually agree that it may be fabricated in multiple sections. A multiple section baseplate shall have machined and doweled mating surfaces which shall be bolted together to ensure accurate field reassembly.

NOTE A baseplate with a nominal length of more than 12 m (40 ft) or a nominal width of more than 4 m (12 ft) may have to be fabricated in multiple sections because of shipping restrictions.

- [•] **7.4.2** If specified, the baseplate shall be designed for column mounting (that is, of sufficient rigidity to be supported at specified points) without continuous grouting under structural members. The baseplate design shall be mutually agreed upon by the purchaser and the vendor.

7.4.3 If a baseplate is provided, it shall extend under the drive-train components so that any leakage from these components is contained within the baseplate.

7.4.4 The mounting plate or plates shall be furnished in accordance with the following.

7.4.4.1 If a piece of equipment has a mass in excess of 250 kg (550 lb), the baseplate shall be supplied with horizontal (axial and lateral) jackscrews, the same size or larger than the vertical jackscrews.

- a) The lugs holding these jackscrews shall be attached to the baseplate in such a manner that they do not interfere with the installation of the equipment, jackscrews, spacers, or shims.
- b) Precautions shall be taken to prevent vertical jackscrews in the equipment feet from marring the shimming surfaces.
- c) Jackscrews shall be stainless steel or plated for corrosion resistance.

7.4.4.2 Alternative methods of lifting equipment for the removal or insertion of shims or for moving equipment horizontally, such as provision for the use of hydraulic jacks, may be proposed. Such arrangements should be proposed for equipment that is too heavy to be lifted or moved horizontally using jackscrews.

7.4.5 Baseplates shall be designed to limit the relative displacement of the shaft end caused by the worst combination of pressure, torque, and allowable piping stress, to 50 μm (0.002 in.). Loads applied during transportation and installation shall not cause permanent deformation (see 6.7 for allowable piping loads).

7.4.6 Baseplates shall conform to the following:

- a) Baseplates shall not be drilled for equipment to be mounted by others,
- b) Baseplates shall be supplied with leveling screws,
- c) Outside corners of baseplates which are in contact with the grout shall have 50 mm (2 in.) minimum radius outside corners (in the plan view),
- d) All machinery mounting pads shall be treated with a rust preventive immediately after machining,
- e) Mounting pads shall extend at least 25 mm (1 in.) beyond the outer three sides of equipment feet,
- f) Mounting pads shall be machined to a finish of 32 μm (125 $\mu\text{in.}$) arithmetic average roughness (Ra) or smoother.

- [•] **7.4.7** Mounting pads shall be provided for the pump and all drive train components, such as motors and gears.

7.4.7.1 The pads shall be larger than the foot of the mounted equipment to allow levelling of the baseplate without removal of the equipment.

7.4.7.2 The pads shall be fully machined flat and parallel.

7.4.7.3 Corresponding surfaces shall be in the same plane within 150 µm/m (0.002 in./ft) of distance between the pads.

[●] **7.4.7.4** If specified, this requirement shall be demonstrated in the pump vendor's shop prior to mounting of the equipment and with the baseplate supported and clamped at the foundation bolt holes only.

NOTE Installed baseplate flatness can be affected by transportation, handling, and installation procedures beyond the vendor's scope. Installation practices in API 686 should be followed. Because of the weight of the equipment, consider shipping the baseplate without the equipment mounted.

7.4.8 The underside of the fabricated decking located under the pump and drive train supports shall be continuous seal welded to the cross members.

7.4.9 The underside mounting surfaces of the baseplate shall be in one plane to permit use of a single-level foundation. If the baseplate is constructed of multiple sections, the mounting pads shall be in one plane after the baseplate sections are doweled and bolted together.

7.4.10 The baseplate shall be provided with lifting lugs for at least a four-point lift. Lifting the baseplate or skid complete with all equipment mounted shall not permanently distort or otherwise damage the baseplate or the equipment mounted on it. The vendor shall advise if a spreader bar is needed, and if equipment should be uncoupled before lifting.

7.4.10.1 The lifting lugs and attachment method shall be designed using a maximum allowable stress of one-third of the specified minimum yield strength of the material. Any lifting lug welds shall be inspected by either liquid penetrant or magnetic particle testing.

7.4.11 Baseplate shall be of the drain-rim or drain-pan type and shall have a raised lip.

7.4.11.1 Connections for a drain shall be tapped DN 50 (NPS 2) minimum in the raised lip at the pump end and shall be located for complete drainage.

7.4.11.2 The pan or upper surface of the baseplate shall be sloped 1:120 minimum toward the drain end.

[●] **7.4.12** If specified, nonskid metal decking covering all walk and work areas shall be provided on the top of the baseplate.

7.4.13 Unless otherwise specified, epoxy grout shall be used for baseplates designed for grouting when installed on concrete foundations. The vendor shall commercially sand blast, in accordance with ISO 8501-1 Grade Sa2 or SSPC SP 6, all grout contact surfaces of the baseplate and coat those surfaces with a primer compatible with epoxy grout. Grouts other than epoxy may require alternative surface preparation.

7.4.14 The bottom of the baseplate between structural members shall be open.

7.4.14.1 If the baseplate is designed for grouting, it shall be provided with at least one grout hole having a clear area of at least 125 cm² (20 in.²) and no dimension less than 75 mm (3 in.) in each bulkhead section.

7.4.14.2 These holes shall be located to permit grouting under all load carrying structural members.

7.4.14.3 If practicable, the holes shall be accessible for grouting with the equipment installed.

7.4.14.4 If located in an area where liquids could impinge on the exposed grout, metallic covers with a minimum thickness of 16 gauge shall be provided for the grout holes.

7.4.14.5 Vent holes at least 13 mm (0.5 in.) in size shall be provided at the highest point in each bulkhead section of the baseplate.

- [•] **7.4.15** If specified, 13 mm (0.5 in.) raised-lip edges shall be provided around the grout holes.

NOTE This is particularly necessary for installations that will be using cementitious grout.

7.4.16 Shims shall not be used under the pump. All pads for drive train components shall be machined to allow for the installation of stainless steel shims at least 3 mm (0.12 in.) thick under each component.

7.4.16.1 If the vendor mounts the components, a set of shims at least 3 mm (0.12 in.) thick shall be supplied.

7.4.16.2 Shim packs shall not be thicker than 13 mm (0.5 in.) nor contain more than 5 shims.

7.4.16.3 All shim packs shall straddle the hold-down bolts and vertical jackscrews and extend at least 6 mm (0.25 in.) beyond the outer edges of the equipment feet.

7.4.16.4 If the vendor does not mount the components, the pads shall not be drilled, and shims shall not be provided.

- [•] **7.4.17** If specified, in addition to shim packs, a stainless steel spacer plate of not less than 6 mm (0.25 in.) thickness, machined on both sides, and of the same length and width as the specific mounting feet, shall be furnished and installed under all equipment feet, including the pump, driver, and any speed increaser or reducer.

- [•] **7.4.18** If specified, the baseplate shall be designed to facilitate the use of optical, laser based or other instruments for accurate leveling in the field. The details of such facilities shall be agreed by the purchaser and vendor.

7.4.18.1 Where the requirement is satisfied by the provisions of leveling pads or targets, they shall be accessible with the baseplate on the foundation and the equipment mounted.

7.4.18.2 Removable protective covers shall be provided.

7.4.18.3 For column mounted baseplate (see 7.4.2) leveling pads or targets shall be located close to the support points.

7.4.18.4 For non-column mounted baseplate, a pad or target shall be located at each corner.

7.4.18.5 When required for long units, additional pads shall be located at intermediate points.

7.4.19 Equipment and baseplates shall be designed for installation in accordance with API 686.

7.4.20 Hold-down bolts used to attach the equipment to the baseplate, and all jackscrews, shall be provided by the vendor.

7.4.21 Unless otherwise specified, anchor bolts shall be supplied by the purchaser.

7.4.22 The anchor bolts shall not be used to fasten equipment to the baseplate.

7.5 Pressure-limiting Valves (PLVs)

7.5.1 PLVs or other protective devices shall be used with all positive displacement pumps.

7.5.1.1 Rupture disks shall not be used.

7.5.1.2 The sizing, selection and installation of pressure limiting valves shall meet the requirements of API 520, Part I and Part II.

7.5.2 Unless otherwise specified, the purchaser shall provide PLVs in accordance with API 526.

7.5.2.1 The vendor shall provide the purchaser with information on recommended flow rate and relieving pressure.

7.5.2.2 The vendor and purchaser should review the purchaser's (or vendor's) valve selection.

7.5.2.3 PLV sizes and settings, including accumulation, shall account for all possible modes of equipment failure and shall meet the requirements of 6.3.2.

[●] **7.5.2.4** If specified, the valve shall be provided by the vendor.

7.5.3 Unless agreed to by the purchaser, pressure limiting valves that are integral with or internal to the pump are not acceptable.

7.6 Controls and Instrumentation

7.6.1 The controls and instrumentation scope of supply shall be supplied and installed as per the purchaser's specifications and on the datasheet.

NOTE See Annex G for a typical piping and instrumentation diagram for MPP skids.

7.6.2 All controls and instrumentation shall be per API 614 and suitable for the electrical classification and the hazard conditions as identified on the datasheet.

7.7 Auxiliary Piping

7.7.1 Auxiliary piping, oil piping, instrument piping and process piping shall be in accordance with the appropriate part of API 614, except as modified in 7.7.2.

7.7.2 Auxiliary piping system materials shall be in accordance with Table 1A through Table 1D of API 614. If space does not permit the use of DN 12, DN 20, DN 25 (NPS ½, NPS ¾, or NPS 1) pipe, seamless tubing may be supplied.

7.7.2.1 A thermal relief valve piped to the purchaser's vent and drain system should be considered for auxiliary piping systems that can be blocked in by a valve closure.

7.7.3 Pipe plugs shall be in accordance with 6.5.4.3 for permanent plugs or 8.4.3.6 for shipping plugs.

7.8 Pulsation and Vibration Control Requirements for Multiphase Skids

7.8.1 General

The interaction of the dynamic flow generated by the MPP with acoustical resonance in piping systems can result in excitation in the pump and piping. This energy can result in pump and piping failures. Refer to API RP 688 for guidance on pulsation and vibration.

7.9 Special Tools

7.9.1 If special tools or fixtures are required to disassemble, assemble, or maintain the equipment, they shall be included in the quotation and provided as part of the initial supply of the equipment.

7.9.1.1 For multiple-unit installations, the requirements for quantities of special tools and fixtures shall be agreed between purchaser and vendor.

7.9.1.2 These, or similar special tools, shall be used, and their use demonstrated, during shop assembly and any required post-test disassembly of the equipment.

7.9.2 If special tools are provided, they shall be firmly attached to the pump or packaged in a separate, rugged metal box or boxes and shall be marked “special tools for (tag/item number)”. Each tool shall be stamped or tagged to indicate its intended use.

8 Inspection, Testing, and Preparation for Shipment

8.1 General

- [•] **8.1.1** The purchaser shall specify the extent of participation in the inspection and testing.
- [•] **8.1.2** If specified, the purchaser’s representative, the vendor’s representative or both shall indicate compliance in accordance with an inspector’s checklist such as that provided in Annex C by initialing, dating, and submitting the completed checklist to the purchaser before shipment.
- 8.1.3** After advance notification to the vendor, the purchaser’s representative shall have entry to all vendor and sub-vendor plants where manufacturing, testing or inspection of the equipment is in progress.
- 8.1.4** The vendor shall notify sub-vendor of the purchaser’s inspection and testing requirements.
- [•] **8.1.5** If specified, the vendor shall provide their standard ITP to the purchaser for review and acceptance.
- [•] **8.1.6** If shop inspection and testing have been specified by the purchaser, the purchaser and the vendor shall coordinate manufacturing hold points and inspector’s visits.
- 8.1.7** The expected dates of testing shall be communicated at least 30 days in advance and the actual dates confirmed as agreed. Unless otherwise agreed, the vendor shall give at least five working days advanced notification of a witnessed or observed inspection or test.

NOTE 1 For smaller pumps where set-up and test time is short, five days’ notice sometimes means the pump is removed from the test stand between preliminary and witness tests.

NOTE 2 All witnessed inspections and tests are hold points. For observed tests, the purchaser can expect to be in the factory longer than for a witnessed test.

- [•] **8.1.8** If specified, witnessed mechanical and performance tests shall require a written notification of a successful preliminary test. The vendor and purchaser shall agree if the machine test set up is to be maintained or if the machine can be removed from the test stand between the preliminary and witnessed tests.

NOTE 1 Many purchasers prefer not to have preliminary tests prior to witnessed tests to understand any difficulties encountered during testing. If this is the case, purchasers need to clearly inform the vendor.

NOTE 2 This is particularly important for MPPs.

8.1.9 Equipment, materials and utilities for the specified inspections and tests shall be provided by the vendor.

8.1.10 The purchaser’s representative shall have access to the vendor’s quality program for review and all major sub-vendors.

8.2 Inspection

8.2.1 General

8.2.1.1 The vendor shall keep the following data available for at least 20 years:

- a) necessary or specified certification of materials, such as test reports (CMTR);
- b) test data and results to verify that the requirements of the specification have been met;

- c) fully identified records of all heat treatment and nondestructive examination (NDT) whether performed in the normal course of manufacture or as part of a repair procedure;
- d) results of quality control tests and inspections;
- e) details of all major weld repairs including weld maps;
- [●] f) if specified, final assembly maintenance and running clearances;
- g) other data specified by the purchaser or required by applicable codes and regulations (see Section 5);
- h) nonconformance reports and corrective actions.

8.2.1.2 Pressure-containing parts shall not be painted until the specified inspection and testing of the parts is complete.

[●] **8.2.1.3** In addition to the requirements of 8.2.2, the purchaser may specify the following:

- a) parts that shall be subjected to surface and subsurface examination; and
- b) the type of examination required, such as magnetic particle, liquid penetrant, radiographic and ultrasonic examination.

8.2.1.4 All running tests and mechanical checks shall be completed prior to the purchaser's final inspection.

8.2.2 Materials Inspection

8.2.2.1 General

8.2.2.1.1 NDT shall be performed as required by the material specification. If additional radiographic, ultrasonic, magnetic particle or liquid penetrant examination of the welds or materials is specified by the purchaser, the methods and acceptance criteria shall be in accordance with the standards shown in Table 4.

- a) Alternative standards may be proposed by the vendor or specified by the purchaser, and they shall be mutually agreed to by both purchaser and vendor.
- b) The welding and material inspection datasheet in Annex A may be used for this purpose.

Table 4—Material Inspection Standards

Type of Inspection	Methods	Acceptance Criteria	
		For Fabrications	For Castings
Visual Inspection (Note 1)	ASME <i>BPVC</i> Section V, Article 9	Note 2	MSS SP-55
Radiography	ASME <i>BPVC</i> Section V, Articles 2 and 22	ASME <i>BPVC</i> Section VIII, Division 1, UW-51 (for 100 % radiography) and UW-52 (for spot radiography)	ASME <i>BPVC</i> Section VIII, Division 1, Appendix 7
Ultrasonic Inspection	ASME <i>BPVC</i> Section V, Articles 5 and 23	ASME <i>BPVC</i> Section VIII, Division 1 Appendix 12	ASME <i>BPVC</i> Section VIII, Division 1, Appendix 7
Magnetic Particle Inspection	ASME <i>BPVC</i> Section V, Articles 7 and 25	ASME <i>BPVC</i> Section VIII, Division 1, Appendix 6	ASME <i>BPVC</i> Section VIII, Division 1, Appendix 7

Table 4—Material Inspection Standards (Continued)

Type of Inspection	Methods	Acceptance Criteria	
		For Fabrications	For Castings
Liquid Penetrant Inspection	ASME <i>BPVC</i> Section V, Articles 6, and 24	ASME <i>BPVC</i> Section VIII, Division 1, Appendix 8	ASME <i>BPVC</i> Section VIII, Division 1, Appendix 7
NOTE 1 For visual inspection, all surfaces shall be inspected. NOTE 2 Acceptance criteria for fabricated parts shall be in accordance with the material specification and the vendor's documented procedures.			

8.2.2.1.2 Plate used in fabrications shall be inspected prior to starting fabrication in accordance with the material standard to which the plate was purchased.

8.2.2.1.3 The NDT shall be done on finished machined surfaces (see Annex A datasheets).

- [•] **8.2.2.1.4** If NDT testing is specified for nodular iron castings, it will be conducted using the magnetic particle and liquid penetrant test methods.

8.2.3 Mechanical Inspection

8.2.3.1 During assembly of the equipment, each component (including integrally cast-in passages) and all piping and auxiliaries shall be inspected to ensure they have been cleaned and are free of foreign materials, corrosion products and mill scale.

8.2.3.2 All oil system components supplied shall meet the cleanliness requirements of Part 3 of API 614.

- [•] **8.2.3.3** If specified, the purchaser may inspect the equipment and all piping and auxiliaries for cleanliness before heads are welded onto vessels, openings in vessels or exchangers are closed, or piping is finally assembled.
- [•] **8.2.3.4** If specified, the hardness of parts, welds, and heat-affected zones shall be verified as being within the allowable values by testing. The method, extent, documentation, and witnessing of the testing shall be mutually agreed upon by the purchaser and the vendor.

8.2.4 Positive Material Identification (PMI)

- [•] **8.2.4.1** If PMI testing has been specified for a fabrication, the components comprising the fabrication, including welds, shall be checked after the fabrication is complete. Testing may be performed prior to any heat treatment.

- [•] **8.2.4.2** If PMI is specified, techniques providing quantitative results shall be used.

8.2.4.3 CMTR's visual stamps or markings shall not be considered as substitutes for PMI testing.

8.2.4.4 PMI results shall be within material specification governing standard(s) limits with allowance for the accuracy of the PMI device as specified by the device vendor.

8.3 Testing

8.3.1 General

8.3.1.1 Equipment shall be tested in accordance with 8.3.2, 8.3.3, or 8.3.4 as appropriate.

- [•] **8.3.1.2** If specified, the vendor shall submit to the purchaser, for review and comment, detailed procedures, and acceptance criteria for all required tests. The time period between submittal of the documents and the running test shall be at least six weeks, unless otherwise agreed.

8.3.1.3 Notification requirements are covered in 8.1.7, however, hydrostatic and running test requirements shall be not less than five working days before the date the equipment will be ready for testing. If the testing is rescheduled, the vendor shall notify the purchaser not less than five working days before the new test date.

8.3.2 Hydrostatic Testing

8.3.2.1 All pressure casing components shall be assembled as a single unit and tested hydrostatically with liquid at a minimum of 1.5 times the MACP, but not less than a gauge pressure of 150 kPa (1.5 bar) (20 psi).

NOTE Casings with dual pressure ratings are sometimes segmentally tested as per 8.3.2.7.

8.3.2.1.1 The test liquid shall be at a higher temperature than the ductile-brittle transition temperature of the material being tested.

NOTE The ductile-brittle transition temperature is the highest temperature at which a material experiences complete brittle fracture without appreciable plastic deformation.

8.3.2.2 If the component handling the pumped liquid is to operate at a temperature at which the strength of a material is below the strength of that material at the testing temperature, the hydrostatic test pressure shall be multiplied by a factor obtained by dividing the allowable working stress for the material at the testing temperature by that at the rated operating temperature.

8.3.2.2.1 The stress values used shall be determined in accordance with those of 6.3.1. For piping, the stress shall conform to ASME B31.3 or ISO 15649 as specified by the user.

8.3.2.2.2 The pressure thus obtained shall then be the minimum pressure at which the hydrostatic test shall be performed. The vendor shall list actual hydrostatic test pressures on datasheets.

8.3.2.2.3 Verify the applicability of this requirement to the material being tested before hydrostatic test, as the properties of many grades of steel do not change appreciably at temperatures up to 200 °C (390 °F).

8.3.2.3 If applicable, tests shall be in accordance with the code or standard to which the part has been designed. If a discrepancy exists between the code test pressure and the test pressure in this standard, the higher pressure shall govern.

8.3.2.4 The chloride content of liquids used to test austenitic stainless steel materials shall not exceed 50 ppm (ppm by mass). To prevent deposition of chlorides on austenitic stainless steel as a result of evaporative drying, all residual liquid shall be removed from tested parts at the conclusion of the test.

NOTE Chloride content is limited to prevent stress corrosion cracking.

8.3.2.5 Tests shall be maintained for a sufficient period of time to permit complete examination of parts under pressure.

8.3.2.5.1 The hydrostatic test shall be considered satisfactory when neither leaks nor seepage through the pressure containing part or joints is observed for a minimum of 30 minutes.

8.3.2.5.2 Large, heavy pressure-containing parts may require a longer testing period to be agreed upon by the purchaser and the vendor.

8.3.2.5.3 Gaskets used during the hydrostatic testing shall be of the same design as supplied with the pump.

8.3.2.5.4 Seepage past internal closures required for testing of segmented cases and operation of a test pump to maintain pressure is acceptable (see 8.3.2.1).

8.3.2.6 All water-side cooling passages shall be tested at a minimum gauge pressure of 1000 kPa (10 bar) (150 psi).

8.3.2.7 Casings with dual pressure ratings may be segmentally tested. Seepage past internal closures or gaskets and operation of a test pump to maintain pressure is acceptable.

8.3.3 Pre-testing Check

8.3.3.1 Oil system components downstream of the filters shall meet the cleanliness requirements of API 614 before any test is started.

8.3.3.2 All joints and connections shall be checked for tightness and any leaks shall be corrected.

8.3.3.3 All warning, protective and control devices used during the test shall be checked and adjusted as required.

8.3.4 Performance Test

8.3.4.1 Unless otherwise specified, tests shall be conducted in accordance with HI Standard 3.6 of, according to the tolerances specified in 8.3.6 in this standard. The vendor shall operate the pump in their shop for sufficient period to obtain complete test data, including speed, discharge pressure, suction pressure, power, and capacity.

[•] **8.3.4.2** If specified, and if the pump is to be operated at variable speeds, the pump shall be tested at speeds within five percentage points of 30, 60, 90, and 100 of the rated speed.

8.3.4.3 The tests specified in 8.3.4.1 apply to the pump only, and the values of power are to be taken as referring to the pump. However, the recorded data and final report may include information on the complete unit, including driver and auxiliary equipment. The purchaser and the vendor shall agree to the test measurements to be recorded on both the driver and the auxiliary equipment.

8.3.4.3.1 If the test facility does not have the capability to meet the rated conditions, the tests shall be run at both the specified discharge pressure with reduced speed and at the rated speed with reduced discharge pressure. The purchaser and the vendor shall agree to the test methods and their limitations prior to performing the tests.

8.3.4.4 If dismantling is necessary to correct pump deficiencies, the pump characteristics affected by the correction shall be reestablished by testing.

8.3.5 Mechanical Run Test

[•] **8.3.5.1** If specified, a mechanical run test shall be performed either before or consecutively following the performance test. The mechanical run test shall be one hour or until oil temperatures have stabilized.

NOTE 1 Machines equipped with ring-oiled or splash lubrication systems do not always reach absolute temperature stabilization during shop tests of short duration. A typical guideline for bearing and lube oil temperature stabilization is not more than 2 °F (1 °C) over a 10 minute period.

NOTE 2 The stabilization temperature does not account for ambient temperature increase.

[•] **8.3.5.2** If specified, the pump shall be mechanically run for four hours. Unless otherwise specified or agreed, this shall be performed at the rated flow.

8.3.5.3 Unless otherwise agreed, the contract shaft seals and bearings shall be used in the machine for the mechanical running test.

8.3.5.4 If replacement or modification of bearings or seals or dismantling of the case to replace or modify other parts is required to correct mechanical or performance deficiencies, the initial test will not be acceptable and the final shop tests shall be run after these deficiencies are corrected.

8.3.6 Test Tolerances

Unless otherwise agreed or specified, when operated on the test stand, pumps shall be within the tolerances as given in Table 5.

Table 5—Test Tolerances

Characteristic	Capacity	Tolerance (%)
at 100 % speed		+3, -0 of rated capacity
at 90 % speed		+3, -0 of rated capacity
at 60 % speed		+5, -0 of rated capacity
at 30 % speed		+10, -0 of rated capacity
rated power (at rated pressure and capacity)		+4
NPSHR (at rated capacity)		+0

8.3.7 Optional Tests

- [●] If specified, the shop tests described in 8.3.7.1 through 8.3.7.4 shall be performed. Test details shall be agreed upon by the purchaser and the vendor.

8.3.7.1 NPSH (NPIP) Test

- [●] If specified, the pump shall be tested for NPSH (NPIP). At rated speed and with NPIPA/NPSHA equal to quoted NPSHR, the pump capacity shall be within three percent of the non-cavitating capacity.

Warning — The pump shall not be run while cavitating.

NOTE 1 Confirm if the mechanical seal included in their scope can operate in a suction lift condition.

NOTE 2 NPSH/NPIP testing is not applicable for MPPs.

8.3.7.2 Complete Unit Test

- [●] If specified, such components as pumps, gears, drivers, and auxiliaries that make up the complete unit shall be tested together. The complete unit test may be performed in place of or in addition to separate tests of individual components.

8.3.7.3 Sound Level Test

- [●] If specified, the sound level test shall be performed in accordance with ISO 3744, or another agreed upon standard.

8.3.7.4 High Discharge Pressure Test

- [●] If specified, the pump will be operated at the PLV set pressure at the maximum rated pump speed and a fluid viscosity agreed to by the vendor and the purchaser to confirm that the pump does not seize under these conditions. A single data point will be collected.

8.3.8 Multiphase Tests

8.3.8.1 Multiphase Fluid Mechanical Test

- [●] a) If specified, a fluid of defined GVF, simulating contract multiphase conditions, will be introduced into the pump/pumping system inlet during this test. Data gathered is as per the mechanical run test.

- b) Test stand conditions and acceptance criteria shall be agreed between the vendor and purchaser.
- c) The vendor shall provide a recommended test procedure as part of the proposal.

8.3.8.2 Gas Slug Test (Dry Run Test)

If specified, a slug test (rapid change from 30 % to 100 % GVF at pump/pumping system inlet) will be performed following the multiphase fluid mechanical test for the designed period of time. Data gathered is as per the multiphase fluid test. Test stand conditions and acceptance criteria shall be mutually agreed between the vendor and purchaser. The vendor shall provide a recommended test procedure as part of the proposal.

8.3.8.3 Factory Acceptance Test

- [•] If specified, controls and instrumentation shall undergo a functional acceptance test, which includes verification of functionality of instrumentation, control, PLC control logic, alarm and shutdown set points.

8.3.9 Test Data

Immediately upon completion of each witnessed mechanical and performance test, copies of the data logged shall be given to the witness.

8.4 Preparation for Shipment

8.4.1 Equipment shall be suitably prepared for the type of shipment specified.

8.4.1.1 Unless otherwise specified, the preparation shall make the equipment suitable for 6 months of outdoor storage from the time of shipment, with no disassembly required before installation, except for inspection of bearings and seals.

8.4.1.2 If storage for a longer period is contemplated, the purchaser will consult with the vendor regarding the recommended procedures to be followed.

8.4.1.3 Removal of the inhibitor and periodic rotation of the pump shaft (per the vendor's recommended procedure) to ease seal and bearing movement, shall be the responsibility of the purchaser.

8.4.2 The vendor shall provide the purchaser with the instructions necessary to preserve the integrity of the storage preparation after the equipment arrives at the job site and before start-up, as described in Chapter 3 of API 686.

8.4.3 The equipment shall be prepared for shipment after all testing and inspection has been completed and the equipment has been released by the purchaser. The preparation shall include that specified in 8.4.3.1 through 8.4.3.10.

8.4.3.1 Except for machined surfaces, all exterior surfaces that may corrode during shipment, storage, or in service, shall be given at least one coat of the vendor's standard paint, unless otherwise specified. The paint shall not contain lead or chromates.

NOTE Austenitic stainless steels are typically not painted.

8.4.3.2 Exterior machined surfaces except for corrosion-resistant material shall be coated with rust preventive.

8.4.3.3 The interior of the equipment shall be clean; free from scale, welding spatter and foreign objects; and, except for corrosion-resistant material, sprayed or flushed with rust preventive that can be removed with solvent. The rust preventive shall be applied through all openings while the shaft is rotated.

8.4.3.4 Internal surfaces of bearing housings and carbon steel oil system components shall be coated with epoxy or alternatively coated with oil-soluble rust preventive that is compatible with the lubricating oil.

8.4.3.5 Flanged openings shall be provided with metal closures at least 5 mm (0.19 in.) thick with elastomeric gaskets and at least four full-diameter bolts. For studed openings, all nuts needed for the intended service shall be used to secure closures.

8.4.3.6 Threaded openings shall be provided with steel caps or hex head steel plugs. In no case shall non-metallic (such as plastic) caps or plugs be used.

NOTE These are shipping plugs; permanent plugs are covered in 6.5.4.3.

8.4.3.7 Lifting points, lifting lugs and baseplate center of gravity shall be clearly identified on the equipment, equipment drawing, or equipment package. The recommended lifting arrangement shall be as described in the installation manual.

8.4.3.8 The equipment shall be identified with item and serial numbers.

8.4.3.8.1 Material shipped separately shall be identified with securely affixed, corrosion-resistant metal tags indicating the item and serial number of the equipment for which it is intended.

8.4.3.8.2 Crated equipment shall be shipped with duplicate packing lists, one inside and one on the outside of the shipping container.

8.4.3.9 Exposed shafts, and shaft couplings shall be protected with a corrosion barrier followed by a separate barrier material to protect against incidental mechanical damage.

8.4.3.10 Loose components shall be placed in plastic bags (or dipped in wax) and contained by cardboard boxes. Loose boxes are to be securely blocked in the shipping container.

8.4.4 Auxiliary piping connections supplied on the purchased equipment shall be impression-stamped or permanently tagged to agree with the vendor's connection table or general arrangement drawing. Service and connection designations shall be indicated.

8.4.5 Bearing assemblies shall be fully protected from the entry of moisture and dirt.

8.4.5.1 If vapor-phase-inhibitor crystals in bags are installed in large cavities to absorb moisture, the bags should be attached in an accessible area for ease of removal.

8.4.5.2 If applicable, bags shall be installed in wire cages attached to flanged covers and bag locations shall be indicated by corrosion-resistant tags attached with stainless steel wire.

8.4.6 One copy of the vendor's installation instructions shall be packed and shipped with the equipment.

8.4.7 Connections on auxiliary piping that are removed for shipment, shall be match marked for ease of reassembly.

[•] **8.4.8** If specified, the fit-up and assembly of machine-mounted piping, intercoolers etc. shall be completed in the vendor's shop prior to shipment.

9 Vendor's Data

9.1 General

9.1.1 The purchaser may specify the content of proposals, meeting frequency and vendor data content/format identified in Annex D. Annex D provides a general outline of information that potentially may be requested by the purchaser.

[•] **9.1.2** If specified, the information specified in Annex D shall be provided.

Annex A
(informative)

Rotary Pump Datasheets

DOCUMENT NUMBER: _____

CLIENT DOCUMENT NUMBER: _____

ROTARY PUMP (API 676-3RD) DATA SHEET U.S. CUSTOMARY					REVISION	0	1	2	3	4	
					DATE						
					BY						
					REV/APPR						
					JOB NO.	ITEM NO.					
					PAGE	1	OF	3	REQ'N NO.		

1	APPLICABLE TO: <input type="checkbox"/> PROPOSAL <input type="checkbox"/> PURCHASE <input type="checkbox"/> AS BUILT	PO NO. _____				
2	END USER _____	UNIT _____				
3	SITE _____	NO. OF PUMPS REQUIRED _____				
4	SERVICE _____	SIZE, MODEL, AND TYPE _____				
5	MANUFACTURER _____	SERIAL NO. _____				
6						
7	NOTE: <input type="radio"/> INDICATES INFORMATION TO BE COMPLETED BY PURCHASER <input type="checkbox"/> BY MANUFACTURER <input checked="" type="radio"/> BY MANUFACTURER OR PURCHASER					
8	GENERAL					
9	NO. MOTORS DRIVEN _____	OTHER DRIVER TYPE _____				
10	PUMP ITEM NO'S _____	PUMP ITEM NO'S _____				
11	MOTOR ITEM NO'S _____	DRIVER ITEM NO'S _____ GEAR ITEM NO'S _____				
12	MOTOR PROVIDED BY _____	DRIVER PROVIDED BY _____ GEAR PROVIDED BY _____				
13	MOTOR MOUNTED BY _____	DRIVER MOUNTED BY _____ GEAR MOUNTED BY _____				
14	MOTOR DATA SHEET NO. _____	DRIVER DATA SHEET NO. _____ GEAR DATA SHEET NO. _____				
15						
16	<input type="radio"/> OPERATING CONDITIONS					
17	MIN NORMAL RATED MAX (1)					
18	<input type="radio"/> CAPACITY: (gpm)	<table border="1" style="width: 100%;"><tr><td></td><td></td><td></td><td></td></tr></table>				
19	<input type="radio"/> OTHER OPER CONDITIONS: (gpm)	<table border="1" style="width: 100%;"><tr><td></td><td></td><td></td><td></td></tr></table>				
20	<input type="radio"/> DISCHARGE PRESSURE: (psig)	<table border="1" style="width: 100%;"><tr><td></td><td></td><td></td><td></td></tr></table>				
21	<input type="radio"/> SUCTION PRESSURE: (psig)	<table border="1" style="width: 100%;"><tr><td></td><td></td><td></td><td></td></tr></table>				
22	<input type="radio"/> DIFFERENTIAL PRESSURE: (psi)	<table border="1" style="width: 100%;"><tr><td></td><td></td><td></td><td></td></tr></table>				
23	<input type="radio"/> NPSH AVAILABLE (ft)					
24	<input type="radio"/> NPIP AVAILABLE (psia)					
25	<input type="radio"/> NPSHa / NPIP DATUM: <input type="radio"/> C.L. SUCTION NOZZLE					
26	<input type="radio"/> TOP OF FOUNDATION					
27	<input type="radio"/> DUTY CYCLE <input type="radio"/> CONTINUOUS <input type="radio"/> INTERMITTENT					
28	(1) Maximum - mechanical design					
29	<input type="checkbox"/> PERFORMANCE					
30	<input type="checkbox"/> RATED CAPACITY (gpm)					
31	<input type="checkbox"/> NPSHa / NPIP REQUIRED (ft) (psia)					
32	<input type="checkbox"/> RATED SPEED (rpm)					
33	<input type="checkbox"/> RATED VOLUMETRIC EFFICIENCY (%)					
34	<input type="checkbox"/> RATED PUMP EFFICIENCY (%)					
35	<input type="checkbox"/> REQUIRED POWER @ MAXIMUM VISCOSITY (BHP)					
36	<input type="checkbox"/> REQUIRED POWER @ PRESSURE LIMITING VALV (BHP)					
37	<input type="checkbox"/> REQUIRED POWER @ RATED CONDITION (BHP)					
38	<input type="checkbox"/> MAXIMUM ALLOWABLE SPEED (rpm)					
39						
40						
41	<input type="checkbox"/> CONSTRUCTION					
42	CONNECTIONS	SIZE ANSI RATING FACING POSITION				
43	SUCTION					
44	DISCHARGE					
45	GLAND FLUSH					
46	DRAINS					
47	VENTS					
48	JACKET					
49	PIPE TO EDGE OF BASEPLATE <input type="checkbox"/> VENT <input type="checkbox"/> DRAINS					
50	<input type="checkbox"/> PUMP TYPE					
51	<input type="radio"/> INTERNAL GEAR <input type="radio"/> TWIN-SCREW <input type="radio"/> VANE <input type="radio"/> LOBE <input type="radio"/> EXTERNAL GEAR <input type="radio"/> 3-SCREW <input type="radio"/> PROGRESSING CAVITY <input type="radio"/> ROTARY GEAR <input type="radio"/> OTHER					
52						
53						
54						
55						
56						
57						

<input type="radio"/> PUMPED FLUID							
<input type="radio"/> TYPE OR NAME OF PUMPED FLUID _____							
MIN NORMAL RATED							
<input type="radio"/> TEMPERATURE: (°F)	<table border="1" style="width: 100%;"><tr><td></td><td></td><td></td></tr></table>						
<input type="radio"/> VAPOR PRESS: (psia)	<table border="1" style="width: 100%;"><tr><td></td><td></td><td></td></tr></table>						
<input type="radio"/> RELATIVE DENSITY (SG):	<table border="1" style="width: 100%;"><tr><td></td><td></td><td></td></tr></table>						
<input type="radio"/> VISCOSITY: (cP)	<table border="1" style="width: 100%;"><tr><td></td><td></td><td></td></tr></table>						
<input type="radio"/> SPECIFIC HEAT _____	Cp (BTU/lb °F)						
<input type="radio"/> CORROSIVE/EROSIVE AGENTS DESCRIPTION							
<input type="radio"/> EROSION _____ <input type="radio"/> CORROSIVE _____							
<input type="radio"/> CHLORIDE CONCENTRATION (ppm) _____							
<input type="radio"/> H ₂ S CONCENTRATION (ppm) _____							
FLUID <input type="radio"/> HAZARDOUS <input type="radio"/> FLAMMABLE <input type="radio"/> OTHER _____							
<input type="radio"/> GAS	<input type="radio"/> ENTRAINED	<input type="radio"/> SLUG FLOW	% BY VOLUME or GVF _____				
<input type="radio"/> SOLIDS PARTICLE SIZE DISTRIBUTION & MIN/MAX _____ (µ)							
<input type="radio"/> SHAPE _____	<input type="radio"/> CONCENTRATION _____	<input type="radio"/> HARDNESS _____					
<input type="radio"/> SITE AND UTILITY DATA							
LOCATION <input type="radio"/> INDOOR <input type="radio"/> OUTDOOR							
<input type="radio"/> HEATED <input type="radio"/> UNHEATED <input type="radio"/> UNDER ROOF							
<input type="radio"/> ELECTRICAL AREA CLASS _____ GROUP _____ DIV _____							
ZONE _____ GROUP _____ TEMP CLASS _____							
<input type="radio"/> WINTERIZATION REQD <input type="radio"/> TROPICALIZATION REQD							
SITE DATA <input type="radio"/> ELEVATION (°F) <input type="radio"/> BAROMETER (psia)							
<input type="radio"/> RANGE OF AMBIENT TEMPS: MIN/MAX _____ / _____ (°F)							
UNUSUAL CONDITIONS							
<input type="radio"/> DUST <input type="radio"/> FUMES <input type="radio"/> SALT ATMOSPHERE							
<input type="radio"/> OTHER _____							
<input type="radio"/> UTILITY CONDITIONS							
ELECTRICITY							
DRIVERS HEATING CONTROL SHUTDOWN							
VOLTAGE	<table border="1" style="width: 100%;"><tr><td></td><td></td><td></td><td></td></tr></table>						
HERTZ	<table border="1" style="width: 100%;"><tr><td></td><td></td><td></td><td></td></tr></table>						
PHASE	<table border="1" style="width: 100%;"><tr><td></td><td></td><td></td><td></td></tr></table>						
COOLING WATER							
INLET RETURN DESIGN MAX Δ							
TEMP (°F)	MAX	<table border="1" style="width: 100%;"><tr><td></td><td></td><td></td><td></td></tr></table>					
PRESS. (psig)	MIN	<table border="1" style="width: 100%;"><tr><td></td><td></td><td></td><td></td></tr></table>					
SOURCE		<table border="1" style="width: 100%;"><tr><td></td><td></td><td></td><td></td></tr></table>					
INSTRUMENT AIR							
PRESSURE (psig) MAX MIN							
		<table border="1" style="width: 100%;"><tr><td></td><td></td><td></td><td></td></tr></table>					
		<table border="1" style="width: 100%;"><tr><td></td><td></td><td></td><td></td></tr></table>					

APPLICABLE SPECIFICATIONS:	
API-676 POSITIVE DISPLACEMENT PUMPS - ROTARY	

58 REMARKS: _____ 59 _____ 60 _____ 61 _____	<input type="checkbox"/> GOVERNING SPECIFICATION (IF DIFFERENT) _____ <input type="checkbox"/> NACE MR0103 (6.13.2.13) <input type="checkbox"/> NACE MR0175 / ISO 15156 <input type="checkbox"/> OTHER _____
---	--

DOCUMENT NUMBER: _____
 CLIENT DOCUMENT NUMBER: _____

ROTARY PUMP (API 676-3RD) DATA SHEET U.S. CUSTOMARY		REVISION 0 1 2 3 4																																																																															
CONSTRUCTION 2 CASING 3 <input type="checkbox"/> MAX. ALLOWABLE CASING PRESS. (6.3.1): _____ (psig) @ _____ (°F) 4 <input type="checkbox"/> MAXIMUM ALLOWABLE SUCTION PRESSURE: _____ (psig) @ _____ (°F) 5 <input type="checkbox"/> HYDROSTATIC TEST PRESSURE - Suct / Disch: _____ / _____ (psig) 6 ROTATING ELEMENTS 7 ROTOR MOUNT <input type="checkbox"/> BTWN. BEARINGS <input type="checkbox"/> OVERHUNG 8 TIMING GEARS <input type="checkbox"/> YES <input type="checkbox"/> NO <input type="checkbox"/> TYPE _____ 9 BEARING TYPE: <input type="checkbox"/> RADIAL <input type="checkbox"/> THRUST 10 BEARING NUMBER: <input type="checkbox"/> RADIAL <input type="checkbox"/> THRUST 11 LUBRICATION TYPE: <input type="radio"/> CONSTANT LEVEL OILERS 12 <input type="radio"/> PUMPED FLUID <input checked="" type="radio"/> RING OIL <input checked="" type="radio"/> OIL SPLASH 13 <input type="radio"/> EXTERNAL <input type="radio"/> OIL FLOOD <input type="radio"/> GREASE 14 <input type="checkbox"/> LUBRICANT Info (Visc, etc) _____ 15 <input type="checkbox"/> MECHANICAL SEALS 16 <input type="checkbox"/> MANUFACTURER AND MODEL _____ 17 <input type="checkbox"/> MANUFACTURER CODE _____ 18 <input type="checkbox"/> API 682 AND DATA SHEETS _____ 19 <input type="checkbox"/> API 682 SEAL FLUSH PLAN _____ 20 <input type="checkbox"/> API 682 SEAL CODE _____ 21 22 DRIVER TYPE 23 <input type="radio"/> INDUCTION MOTOR <input type="radio"/> STEAM TURBINE <input type="radio"/> GEAR <input type="radio"/> OTHER _____ 24 DRIVE MECHANISM 25 <input type="radio"/> DIRECT-COUPLED <input type="radio"/> ASD <input type="radio"/> OTHER _____ 26 <input checked="" type="checkbox"/> COUPLING MANUFACTURER _____ 27 <input checked="" type="checkbox"/> COUPLING TYPE _____ 28 <input type="checkbox"/> RATING (MAX TORQUE) _____ <input checked="" type="checkbox"/> MODEL _____ 29 <input checked="" type="checkbox"/> SPACER LENGTH _____ (IN) <input checked="" type="checkbox"/> S.F. _____ 30 <input type="checkbox"/> COUPLING BALANCED <input type="radio"/> MANF STD <input type="radio"/> AGMA 9000 CLASS 10 (7.2.3) 31 <input type="checkbox"/> COUPLING PER API 671 (7.2.4) 32 <input type="checkbox"/> COUPLING HUB ATTACHMENT 33 <input type="radio"/> STRAIGHT <input type="radio"/> KEYED <input type="radio"/> TAPERED 34 COUPLING GUARD TYPE 35 <input type="radio"/> STEEL <input type="radio"/> BRASS <input type="radio"/> NON-METALLIC <input type="radio"/> OTHER _____ 36 <input checked="" type="checkbox"/> NON SPARK COUPLING GUARD (7.2.15) _____ 37 38 <input type="radio"/> MOTOR DRIVER (SEE MOTOR DATA SHEET) 39 <input type="radio"/> IEEE 841 <input type="radio"/> API 541 <input type="radio"/> API 546 <input type="radio"/> OTHER _____ 40 <input type="radio"/> ASD SUPPLIED BY <input type="radio"/> PURCHASER <input type="radio"/> MOTOR SUPPLIER 41 <input type="checkbox"/> MANUFACTURER _____ <input type="checkbox"/> TYPE _____ 42 <input type="checkbox"/> FRAME _____ <input checked="" type="checkbox"/> ENCLOSURE _____ 43 <input type="checkbox"/> HORIZONTAL <input checked="" type="checkbox"/> VERTICAL 44 (HP) _____ (rpm) 45 VOLTS _____ PHASE _____ HERTZ _____ SERVICE FACTOR _____ 46 <input type="checkbox"/> VARIABLE SPEED RANGE _____ (rpm) 47 <input type="checkbox"/> MINIMUM STARTING VOLTAGE (7.1.2.2) 48 <input type="checkbox"/> INSULATION _____ <input type="checkbox"/> TEMP. RISE _____ 49 <input type="checkbox"/> FULL LOAD AMPS _____ 50 <input type="checkbox"/> LOCKED ROTOR AMPS _____ 51 <input type="checkbox"/> STARTING METHOD _____	MATERIALS <input type="checkbox"/> MIN DESIGN METAL TEMP (6.13.6.1) _____ (°F) <input type="checkbox"/> CASING _____ <input type="checkbox"/> STATOR / LINER _____ <input type="checkbox"/> END PLATES _____ <input type="checkbox"/> ROTOR (S) _____ <input type="checkbox"/> VANES _____ <input type="checkbox"/> SHAFT _____ <input type="checkbox"/> SLEEVE (S) _____ <input type="checkbox"/> GLAND (S) _____ <input type="checkbox"/> BEARING HOUSING _____ <input type="checkbox"/> TIMING GEARS _____ <input type="checkbox"/> ELASTOMERS / GASKETS _____ <input type="checkbox"/> CONTROLLED HARDNESS REQUIRED (6.13.2.13) _____ QA INSPECTION AND TEST <input type="checkbox"/> SPECIAL MATERIAL TESTS (See design codes + weld + inspection sheet) <input type="checkbox"/> LOW AMBIENT TEMP. MATERIALS TESTS (6.13.6.5) <input type="checkbox"/> COMPLIANCE WITH INSPECTORS CHECK LIST <input type="checkbox"/> CERTIFICATION OF MATERIALS (user to define affected components in remarks) <input type="checkbox"/> SURFACE / SUBSURFACE EXAM'S (user defines affected components in remarks) <input type="checkbox"/> RADIOGRAPHY _____ <input type="checkbox"/> ULTRASONIC _____ <input type="checkbox"/> MAGNETIC PARTICLE _____ <input type="checkbox"/> LIQUID PENETRANT _____ <input type="checkbox"/> COMPONENT PMI _____ <input type="checkbox"/> HARDNESS OF PARTS, WELDS & HEAT AFFECTED ZONES <input type="checkbox"/> VENDOR SUBMIT TEST PROCEDURES (8.3.1.2) <input type="checkbox"/> SUPPLIER TO KEEP REPAIR AND HT RECORDS (8.2.1.1) <table style="width:100%; border-collapse: collapse;"> <thead> <tr> <th style="width:60%;"></th> <th style="width:10%; text-align: center;">NON-WIT</th> <th style="width:10%; text-align: center;">WIT</th> <th style="width:10%; text-align: center;">OBSERV</th> </tr> </thead> <tbody> <tr> <td><input type="checkbox"/> SHOP INSPECTION (8.1)</td> <td style="text-align: center;"><input type="checkbox"/></td> <td style="text-align: center;"><input type="checkbox"/></td> <td style="text-align: center;"><input type="checkbox"/></td> </tr> <tr> <td><input type="checkbox"/> HYDROSTATIC (8.3.2)</td> <td style="text-align: center;"><input type="checkbox"/></td> <td style="text-align: center;"><input type="checkbox"/></td> <td style="text-align: center;"><input type="checkbox"/></td> </tr> <tr> <td style="padding-left: 20px;">WITH WETTING AGENT</td> <td style="text-align: center;"><input type="checkbox"/></td> <td style="text-align: center;"><input type="checkbox"/></td> <td style="text-align: center;"><input type="checkbox"/></td> </tr> <tr> <td><input type="checkbox"/> PERFORMANCE (8.3.4)</td> <td style="text-align: center;"><input type="checkbox"/></td> <td style="text-align: center;"><input type="checkbox"/></td> <td style="text-align: center;"><input type="checkbox"/></td> </tr> <tr> <td><input type="checkbox"/> RETEST ON SEAL LEAKAGE</td> <td style="text-align: center;"><input type="checkbox"/></td> <td style="text-align: center;"><input type="checkbox"/></td> <td style="text-align: center;"><input type="checkbox"/></td> </tr> <tr> <td><input type="checkbox"/> NPSH / NPIP (8.3.7.1)</td> <td style="text-align: center;"><input type="checkbox"/></td> <td style="text-align: center;"><input type="checkbox"/></td> <td style="text-align: center;"><input type="checkbox"/></td> </tr> <tr> <td><input type="checkbox"/> TRUE PEAK VELOCITY DATA</td> <td style="text-align: center;"><input type="checkbox"/></td> <td style="text-align: center;"><input type="checkbox"/></td> <td style="text-align: center;"><input type="checkbox"/></td> </tr> <tr> <td><input type="checkbox"/> COMPLETE UNIT TEST (8.3.7.2)</td> <td style="text-align: center;"><input type="checkbox"/></td> <td style="text-align: center;"><input type="checkbox"/></td> <td style="text-align: center;"><input type="checkbox"/></td> </tr> <tr> <td><input type="checkbox"/> SOUND LEVEL TEST (8.3.7.3)</td> <td style="text-align: center;"><input type="checkbox"/></td> <td style="text-align: center;"><input type="checkbox"/></td> <td style="text-align: center;"><input type="checkbox"/></td> </tr> <tr> <td><input type="checkbox"/> CLEANLINESS PRIOR TO FINAL ASSEMBLY (8.2.3.3)</td> <td style="text-align: center;"><input type="checkbox"/></td> <td style="text-align: center;"><input type="checkbox"/></td> <td style="text-align: center;"><input type="checkbox"/></td> </tr> <tr> <td><input type="checkbox"/> HIGH DISCHARGE PRESSURE @ PLV</td> <td style="text-align: center;"><input type="checkbox"/></td> <td style="text-align: center;"><input type="checkbox"/></td> <td style="text-align: center;"><input type="checkbox"/></td> </tr> <tr> <td><input type="checkbox"/> CHECK FOR CO-PLANAR AT</td> <td style="text-align: center;"><input type="checkbox"/></td> <td style="text-align: center;"><input type="checkbox"/></td> <td style="text-align: center;"><input type="checkbox"/></td> </tr> <tr> <td><input type="checkbox"/> MOUNTING PAD SURFACES (7.4.7)</td> <td style="text-align: center;"><input type="checkbox"/></td> <td style="text-align: center;"><input type="checkbox"/></td> <td style="text-align: center;"><input type="checkbox"/></td> </tr> <tr> <td><input type="checkbox"/> 1 HR MECHANICAL RUN TEST AFTER OIL TEMP STABLE (8.3.5.1)</td> <td style="text-align: center;"><input type="checkbox"/></td> <td style="text-align: center;"><input type="checkbox"/></td> <td style="text-align: center;"><input type="checkbox"/></td> </tr> <tr> <td><input type="checkbox"/> 4 HR. MECH RUN AFTER OIL TEMP STABLE(8.3.5.2)</td> <td style="text-align: center;"><input type="checkbox"/></td> <td style="text-align: center;"><input type="checkbox"/></td> <td style="text-align: center;"><input type="checkbox"/></td> </tr> <tr> <td><input type="checkbox"/> AUXILIARY EQUIPMENT TEST (8.3.4.3)</td> <td style="text-align: center;"><input type="checkbox"/></td> <td style="text-align: center;"><input type="checkbox"/></td> <td style="text-align: center;"><input type="checkbox"/></td> </tr> <tr> <td><input type="checkbox"/> OTHER _____</td> <td style="text-align: center;"><input type="checkbox"/></td> <td style="text-align: center;"><input type="checkbox"/></td> <td style="text-align: center;"><input type="checkbox"/></td> </tr> <tr> <td><input type="checkbox"/> TEST WITH SUBSTITUTE SEAL (8.3.5.3)</td> <td style="text-align: center;"><input type="checkbox"/></td> <td style="text-align: center;"><input type="checkbox"/></td> <td style="text-align: center;"><input type="checkbox"/></td> </tr> <tr> <td><input type="checkbox"/> SUPPLIER SUBMIT TEST DATA WITHIN 24 HOURS</td> <td style="text-align: center;"><input type="checkbox"/></td> <td style="text-align: center;"><input type="checkbox"/></td> <td style="text-align: center;"><input type="checkbox"/></td> </tr> </tbody> </table>		NON-WIT	WIT	OBSERV	<input type="checkbox"/> SHOP INSPECTION (8.1)	<input type="checkbox"/>	<input type="checkbox"/>	<input type="checkbox"/>	<input type="checkbox"/> HYDROSTATIC (8.3.2)	<input type="checkbox"/>	<input type="checkbox"/>	<input type="checkbox"/>	WITH WETTING AGENT	<input type="checkbox"/>	<input type="checkbox"/>	<input type="checkbox"/>	<input type="checkbox"/> PERFORMANCE (8.3.4)	<input type="checkbox"/>	<input type="checkbox"/>	<input type="checkbox"/>	<input type="checkbox"/> RETEST ON SEAL LEAKAGE	<input type="checkbox"/>	<input type="checkbox"/>	<input type="checkbox"/>	<input type="checkbox"/> NPSH / NPIP (8.3.7.1)	<input type="checkbox"/>	<input type="checkbox"/>	<input type="checkbox"/>	<input type="checkbox"/> TRUE PEAK VELOCITY DATA	<input type="checkbox"/>	<input type="checkbox"/>	<input type="checkbox"/>	<input type="checkbox"/> COMPLETE UNIT TEST (8.3.7.2)	<input type="checkbox"/>	<input type="checkbox"/>	<input type="checkbox"/>	<input type="checkbox"/> SOUND LEVEL TEST (8.3.7.3)	<input type="checkbox"/>	<input type="checkbox"/>	<input type="checkbox"/>	<input type="checkbox"/> CLEANLINESS PRIOR TO FINAL ASSEMBLY (8.2.3.3)	<input type="checkbox"/>	<input type="checkbox"/>	<input type="checkbox"/>	<input type="checkbox"/> HIGH DISCHARGE PRESSURE @ PLV	<input type="checkbox"/>	<input type="checkbox"/>	<input type="checkbox"/>	<input type="checkbox"/> CHECK FOR CO-PLANAR AT	<input type="checkbox"/>	<input type="checkbox"/>	<input type="checkbox"/>	<input type="checkbox"/> MOUNTING PAD SURFACES (7.4.7)	<input type="checkbox"/>	<input type="checkbox"/>	<input type="checkbox"/>	<input type="checkbox"/> 1 HR MECHANICAL RUN TEST AFTER OIL TEMP STABLE (8.3.5.1)	<input type="checkbox"/>	<input type="checkbox"/>	<input type="checkbox"/>	<input type="checkbox"/> 4 HR. MECH RUN AFTER OIL TEMP STABLE(8.3.5.2)	<input type="checkbox"/>	<input type="checkbox"/>	<input type="checkbox"/>	<input type="checkbox"/> AUXILIARY EQUIPMENT TEST (8.3.4.3)	<input type="checkbox"/>	<input type="checkbox"/>	<input type="checkbox"/>	<input type="checkbox"/> OTHER _____	<input type="checkbox"/>	<input type="checkbox"/>	<input type="checkbox"/>	<input type="checkbox"/> TEST WITH SUBSTITUTE SEAL (8.3.5.3)	<input type="checkbox"/>	<input type="checkbox"/>	<input type="checkbox"/>	<input type="checkbox"/> SUPPLIER SUBMIT TEST DATA WITHIN 24 HOURS	<input type="checkbox"/>	<input type="checkbox"/>	<input type="checkbox"/>
	NON-WIT	WIT	OBSERV																																																																														
<input type="checkbox"/> SHOP INSPECTION (8.1)	<input type="checkbox"/>	<input type="checkbox"/>	<input type="checkbox"/>																																																																														
<input type="checkbox"/> HYDROSTATIC (8.3.2)	<input type="checkbox"/>	<input type="checkbox"/>	<input type="checkbox"/>																																																																														
WITH WETTING AGENT	<input type="checkbox"/>	<input type="checkbox"/>	<input type="checkbox"/>																																																																														
<input type="checkbox"/> PERFORMANCE (8.3.4)	<input type="checkbox"/>	<input type="checkbox"/>	<input type="checkbox"/>																																																																														
<input type="checkbox"/> RETEST ON SEAL LEAKAGE	<input type="checkbox"/>	<input type="checkbox"/>	<input type="checkbox"/>																																																																														
<input type="checkbox"/> NPSH / NPIP (8.3.7.1)	<input type="checkbox"/>	<input type="checkbox"/>	<input type="checkbox"/>																																																																														
<input type="checkbox"/> TRUE PEAK VELOCITY DATA	<input type="checkbox"/>	<input type="checkbox"/>	<input type="checkbox"/>																																																																														
<input type="checkbox"/> COMPLETE UNIT TEST (8.3.7.2)	<input type="checkbox"/>	<input type="checkbox"/>	<input type="checkbox"/>																																																																														
<input type="checkbox"/> SOUND LEVEL TEST (8.3.7.3)	<input type="checkbox"/>	<input type="checkbox"/>	<input type="checkbox"/>																																																																														
<input type="checkbox"/> CLEANLINESS PRIOR TO FINAL ASSEMBLY (8.2.3.3)	<input type="checkbox"/>	<input type="checkbox"/>	<input type="checkbox"/>																																																																														
<input type="checkbox"/> HIGH DISCHARGE PRESSURE @ PLV	<input type="checkbox"/>	<input type="checkbox"/>	<input type="checkbox"/>																																																																														
<input type="checkbox"/> CHECK FOR CO-PLANAR AT	<input type="checkbox"/>	<input type="checkbox"/>	<input type="checkbox"/>																																																																														
<input type="checkbox"/> MOUNTING PAD SURFACES (7.4.7)	<input type="checkbox"/>	<input type="checkbox"/>	<input type="checkbox"/>																																																																														
<input type="checkbox"/> 1 HR MECHANICAL RUN TEST AFTER OIL TEMP STABLE (8.3.5.1)	<input type="checkbox"/>	<input type="checkbox"/>	<input type="checkbox"/>																																																																														
<input type="checkbox"/> 4 HR. MECH RUN AFTER OIL TEMP STABLE(8.3.5.2)	<input type="checkbox"/>	<input type="checkbox"/>	<input type="checkbox"/>																																																																														
<input type="checkbox"/> AUXILIARY EQUIPMENT TEST (8.3.4.3)	<input type="checkbox"/>	<input type="checkbox"/>	<input type="checkbox"/>																																																																														
<input type="checkbox"/> OTHER _____	<input type="checkbox"/>	<input type="checkbox"/>	<input type="checkbox"/>																																																																														
<input type="checkbox"/> TEST WITH SUBSTITUTE SEAL (8.3.5.3)	<input type="checkbox"/>	<input type="checkbox"/>	<input type="checkbox"/>																																																																														
<input type="checkbox"/> SUPPLIER SUBMIT TEST DATA WITHIN 24 HOURS	<input type="checkbox"/>	<input type="checkbox"/>	<input type="checkbox"/>																																																																														

52 <input type="checkbox"/> LUBE _____ 53 BEARINGS (TYPE/NUMBER): _____ 54 <input type="checkbox"/> RADIAL _____ / _____ 55 <input type="checkbox"/> THRUST _____ / _____ 56 _____ 57 _____	<input type="checkbox"/> INCLUDE PLOTTED VIBRATION SPECTRA <input type="checkbox"/> RECORD FINAL ASSEMBLY RUNNING CLEARANCES (8.2.1.1f) <input type="checkbox"/> PERFORMANCE CURVE & DATA APPROVAL PRIOR TO SHIPMENT (8.3.9) <input type="checkbox"/> REDUCED SPEED TEST REQUIRED
--	--

DOCUMENT NUMBER: _____ CLIENT DOCUMENT NUMBER: _____																																									
<table border="1" style="width:100%; border-collapse: collapse;"> <tr> <td style="width:25%;">REVISION</td> <td style="width:12.5%;">0</td> <td style="width:12.5%;">1</td> <td style="width:12.5%;">2</td> <td style="width:12.5%;">3</td> <td style="width:12.5%;">4</td> </tr> <tr> <td>DATE</td> <td></td> <td></td> <td></td> <td></td> <td></td> </tr> <tr> <td>BY</td> <td></td> <td></td> <td></td> <td></td> <td></td> </tr> <tr> <td>REV/APPR</td> <td></td> <td></td> <td></td> <td></td> <td></td> </tr> <tr> <td>JOB NO.</td> <td colspan="3">_____</td> <td>ITEM NO.</td> <td>_____</td> </tr> <tr> <td>PAGE</td> <td>3</td> <td>OF</td> <td>3</td> <td>REQ'N NO.</td> <td>_____</td> </tr> </table>						REVISION	0	1	2	3	4	DATE						BY						REV/APPR						JOB NO.	_____			ITEM NO.	_____	PAGE	3	OF	3	REQ'N NO.	_____
REVISION	0	1	2	3	4																																				
DATE																																									
BY																																									
REV/APPR																																									
JOB NO.	_____			ITEM NO.	_____																																				
PAGE	3	OF	3	REQ'N NO.	_____																																				
<h3 style="margin: 0;">ROTARY PUMP (API 676-3RD)</h3> <h4 style="margin: 0;">DATA SHEET</h4> <h5 style="margin: 0;">U.S. CUSTOMARY</h5>																																									
1	PIPING & APPURTENANCES			PREPARATION FOR SHIPMENT																																					
2	MANIFOLD PIPING FOR PURCHASER CONNECTION			<input type="checkbox"/> DOMESTIC <input type="checkbox"/> EXPORT <input type="checkbox"/> EXPORT BOXING REQ'D <input type="checkbox"/> OUTDOOR STORAGE MORE THAN 6 MONTHS																																					
3	<input type="checkbox"/> VENT <input type="checkbox"/> DRAIN <input type="checkbox"/> STEAM / COOLING WATER <input type="checkbox"/> HEATING JACKET REQ'D. (6.3.6) <input checked="" type="checkbox"/> COOLING REQ'D			SURFACE PREPARATION AND PAINT																																					
4	<input type="checkbox"/> PIPE <input checked="" type="checkbox"/> TUBING; FITTINGS _____ <input checked="" type="checkbox"/> C.S. <input type="checkbox"/> GALVANIZED <input type="checkbox"/> S. STEEL <input type="checkbox"/> VALVES <input type="checkbox"/> CARBON STEEL <input type="checkbox"/> S. STEEL			<input type="checkbox"/> MANUFACTURER'S STANDARD <input type="checkbox"/> OTHER (SEE BELOW) <input type="checkbox"/> SPECIFICATION NO. _____																																					
5	<input checked="" type="checkbox"/> FLANGES REQUIRED IN PLACE OF SOCKET WELD UNIONS <input checked="" type="checkbox"/> MOUNT SEAL POT OFF BASEPLATE			PUMP: (8.4.3.1) <input type="checkbox"/> PRIMER _____ <input type="checkbox"/> FINISH COAT _____																																					
6	CONNECTION BOLTING <input type="checkbox"/> CADMIUM PLATED BOLTS PROHIBITED			BASEPLATE: (8.4.3.1) <input type="checkbox"/> PRIMER _____ <input type="checkbox"/> FINISH COAT _____																																					
7	<input type="checkbox"/> PTFE COATING <input type="checkbox"/> ASTM A153 GALVANIZED <input type="checkbox"/> PAINTED <input type="checkbox"/> SS																																								
8	HEATING AND COOLING			WEIGHTS (lb)																																					
9	HEATING MEDIUM: <input type="checkbox"/> STEAM <input type="checkbox"/> OTHER			<input type="checkbox"/> PUMP <input type="checkbox"/> BASE <input type="checkbox"/> GEAR <input type="checkbox"/> DRIVER TOTAL WEIGHT _____																																					
10	<input checked="" type="checkbox"/> STEAM JACKET/COOLING WATER PRES: _____ (psig) @ _____ (°F)			BASEPLATE																																					
11	COOLING WATER REQUIREMENTS: <input type="checkbox"/> BEARING HOUSING _____ (gpm) @ _____ (psig)			<input type="checkbox"/> BY PUMP MANUFACTURER <input type="checkbox"/> SUITABLE FOR EPOXY GROUT <input type="checkbox"/> EXTENDED FOR _____																																					
12	<input type="checkbox"/> LUBE OIL COOLER _____ (gpm) @ _____ (psig)			<input type="checkbox"/> DRAIN-RIM <input type="checkbox"/> DRAIN-PAN <input type="checkbox"/> NON-GROUT CONSTRUCTION (7.4.2)																																					
13	<input type="checkbox"/> SEAL OIL COOLER _____ (gpm) @ _____ (psig)			OTHER PURCHASER REQUIREMENTS																																					
14	<input type="checkbox"/> OTHER _____ (gpm) @ _____ (psig)			NAMEPLATE UNITS <input type="checkbox"/> U.S. CUSTOMARY <input type="checkbox"/> SI <input type="checkbox"/> RELIEF VALVES BY PUMP MFRG <input type="checkbox"/> INTERNAL <input type="checkbox"/> EXTERNAL PIPING FOR SEAL FLUSH FURNISHED BY: <input type="checkbox"/> PUMP VENDOR <input type="checkbox"/> OTHERS																																					
15	TOTAL COOLING WATER _____ (gpm) @ _____ (psig)			PIPING FOR COOLING/HEATING FURNISHED BY: <input type="checkbox"/> PUMP VENDOR <input type="checkbox"/> OTHERS <input type="checkbox"/> PROVIDE TECHNICAL DATA MANUAL																																					
16	INSTRUMENTATION			<input checked="" type="checkbox"/> INSTALLATION LIST IN PROPOSAL (9.2.3.1)																																					
17	<input type="checkbox"/> ACCELEROMETER(S) _____																																								
18	<input type="checkbox"/> PROVISION FOR MTG ONLY _____																																								
19	<input type="checkbox"/> FLAT SURFACE REQUIRED _____			REMARKS:																																					
20	<input type="checkbox"/> RADIAL BEARING TEMP. <input type="checkbox"/> THRUST BEARING TEMP.																																								
21	<input type="checkbox"/> TEMP. GAUGES (WITH THERMOWELLS) _____																																								
22	<input type="checkbox"/> PRESSURE GAUGE TYPE _____ <input type="checkbox"/> OTHER _____																																								
23	REMARKS:																																								
24	_____																																								
25	_____																																								
26	_____																																								
27	_____																																								
28	_____																																								
29	_____																																								
30	_____																																								
31	_____																																								
32	_____																																								
33	_____																																								
34	_____																																								
35	_____																																								
36	_____																																								
37	_____																																								
38	_____																																								
39	_____																																								
40	_____																																								
41	_____																																								
42	_____																																								
43	_____																																								
44	_____																																								
45	_____																																								
46	_____																																								
47	_____																																								
48	_____																																								
49	_____																																								

**MULTIPHASE
PUMP DATA SHEET (API 676 3rd Ed.)
U.S. CUSTOMARY**

DOCUMENT NUMBER: _____
CLIENT DOCUMENT NUMBER: _____

	0	1	2	3	4
REVISION					
DATE					
BY					
REVI/APPR					
JOB NO.	ITEM NO. _____				
PAGE 1 OF 5	REQ'N NO. _____				

1

2 APPLICABLE TO: PROPOSAL PURCHASE AS BUILT

3 FOR _____ UNIT _____

4 SITE _____ SERIAL NO. _____

5 SERVICE _____ NO. REQUIRED _____

6 MANUFACTURER _____ MODEL _____ DRIVER _____

7 NOTE: INDICATES INFORMATION TO BE COMPLETED BY PURCHASER BY MANUFACTURER BY MANUFACTURER OR PURCHASER

OPERATING CONDITIONS	GAS ANALYSIS							
9 See note in remarks	MIN	NORM.	RATED	MAX (1)	GAS ANALYSIS	NOR-	MAX-	REMARKS
10 <input type="radio"/> CAPACITY: (BPD)						<input type="radio"/> MOL %	MAL	
11 <input type="radio"/> OTHER CAPACITY: (gpm)								
12 <input type="radio"/> SUCTION PRESSURE: (psig)					M.W.			
13 <input type="radio"/> DISCHARGE PRESSURE: (psig)					AIR	28.966		
14 <input type="radio"/> DIFFERENTIAL PRESSURE (psi)					OXYGEN	32.000		
15 <input type="radio"/> DUTY CYCLE <input type="radio"/> CONTINUOUS <input type="radio"/> INTERMITTENT					NITROGEN	28.016		
16 (1) Maximum - mechanical design					WATER VAPOR	18.016		
17 PUMPED FLUID					CARBON MONOXIDE	28.010		
18 <input type="radio"/> TYPE OR NAME OF PUMPED FLUID					CARBON DIOXIDE	44.010		
19 MIN NORMAL RATED					HYDROGEN SULFIDE	34.076		
20 <input type="radio"/> TEMPERATURE: (°F)					HYDROGEN	2.016		
21 <input type="radio"/> VAPOR PRESS.: (psia)					METHANE	16.042		
22 <input type="radio"/> RELATIVE DENSITY (SG):					ETHYLENE	28.052		
23 <input type="radio"/> VISCOSITY: (cP)					ETHANE	30.068		
24 <input type="radio"/> SPECIFIC HEAT _____ Cp (BTU/lb °F)					PROPYLENE	42.078		
25 <input type="radio"/> CORROSIVE/EROSIVE AGENTS					PROPANE	44.094		
26 <input type="radio"/> CHLORIDE CONCENTRATION (ppm)					i-BUTANE	58.120		
27 <input type="radio"/> H ₂ S CONCENTRATION (ppm)					n-BUTANE	58.120		
28 FLUID <input type="radio"/> HAZARDOUS <input type="radio"/> FLAMMABLE <input type="radio"/> OTHER					i-PENTANE	72.146		
29 <input type="radio"/> EROSION <input type="radio"/> CORROSIVE					n-PENTANE	72.146		
30 MULTIPHASE CONDITIONS					HEXANE PLUS			
31 <input type="radio"/> GAS DESCRIPTION _____ (SEE GAS ANALYSIS)								
32 <input type="radio"/> SETTLE OUT PRESSURE _____ (psia)								
33 <input type="radio"/> GAS VOLUME or GVF % MIN MAX								
34 <input type="radio"/> ENTRAINED <input type="radio"/> SLUG FLOW <input type="radio"/> OTHER								
35 <input type="radio"/> SOLIDS PARTICLE SIZE DISTRIBUTION & MIN/MAX _____ (μ)								
36 <input type="radio"/> CONCENTRATION _____ <input type="radio"/> HARDNESS _____								
37 <input type="radio"/> SHAPE _____					TOTAL			
38 PERFORMANCE					AVG. MOL. WT.			
39 <input type="checkbox"/> RATED CAPACITY (gpm) _____					SUPPLIER WITH UNIT RESPONSIBILITY			
40 <input type="checkbox"/> RATED SPEED (rpm) _____					<input type="radio"/> PUMP MANUFACTURER <input type="radio"/> OTHER			
41 <input type="checkbox"/> RATED VOLUMETRIC EFFICIENCY (%) _____					APPLICABLE SPECIFICATIONS:			
42 <input type="checkbox"/> RATED PUMP EFFICIENCY (%) _____					API 676 POSITIVE DISPLACEMENT ROTARY PUMPS			
43 <input type="checkbox"/> REQUIRED POWER @ MAXIMUM VISCOSITY (BHP) _____					<input type="radio"/> GOVERNING SPECIFICATION (IF DIFFERENT)			
44 <input type="checkbox"/> REQUIRED POWER @ PRESSURE LIMITING (BHP) _____					<input type="radio"/> MOTOR (See Page 6)			
45 <input type="checkbox"/> REQUIRED POWER @ RATED CONDITION (BHP) _____					<input type="radio"/> NACE MR0103 (6.13.2.13) <input type="radio"/> NACE MR0175 / ISO 15156			
46 <input type="checkbox"/> MAXIMUM ALLOWABLE SPEED (rpm) _____					<input type="radio"/> NOISE _____ SOUND LEVEL _____ dB @ _____			
47					LUBE AND SEAL OIL CIRCULATION SYSTEMS (API 614 chapter 3)			
48 REMARKS: Note: refer to user fluid flow data sheet, if provided					<input type="radio"/> LUBE SYSTEM <input type="radio"/> SEAL OIL SYSTEMS (plan 54) <input type="radio"/> OTHER			
49					PAINTING: (8.4.3.1)			
50					<input type="radio"/> MANUFACTURER'S STD. <input type="radio"/> OTHER			
51					PREPARE FOR SHIPMENT: (8.4)			
52					<input type="radio"/> DOMESTIC <input type="radio"/> EXPORT <input type="radio"/> EXPORT BOXING REQ'D			
53					<input type="radio"/> LONG TERM STORAGE FOR _____ MONTHS			
54								

DOCUMENT NUMBER: _____
 CLIENT DOCUMENT NUMBER: _____

MULTIPHASE PUMP DATA SHEET (API 676 3rd Ed.) U.S. CUSTOMARY		REVISION	0	1	2	3	4																																																																																																																														
		DATE																																																																																																																																			
		BY																																																																																																																																			
		REVI/APPR																																																																																																																																			
		JOB NO.			ITEM NO.																																																																																																																																
		PAGE	2	OF	5	REQ'N NO.																																																																																																																															
<p>1 LOCATION:</p> <p>2 <input type="radio"/> INDOOR <input type="radio"/> HEATED <input type="radio"/> UNDER ROOF</p> <p>3 <input type="radio"/> OUTDOOR <input type="radio"/> UNHEATED <input type="radio"/> PARTIAL SIDES</p> <p>4 <input type="radio"/> GRADE <input type="radio"/> MEZZANINE <input type="radio"/> _____</p> <p>5 <input type="radio"/> ELECTRICAL AREA CLASS <input type="radio"/> NON-HAZARDOUS</p> <p>6 CL _____ GR _____ DIV. _____ TEMP CLASS _____</p> <p>7 <input type="radio"/> WINTERIZATION REQ'D. <input type="radio"/> TROPICALIZATION REQ'D.</p> <p>8 SITE DATA:</p> <p>9 <input type="radio"/> ELEVATION _____ (ft) BAROMETER _____ (psia)</p> <p>10 <input type="radio"/> RANGE OF AMBIENT TEMPS.:</p> <p>11 _____ DRY BULB _____ WET BULB</p> <p>12 SITE RATED (°F) _____</p> <p>13 NORMAL (°F) _____</p> <p>14 MAXIMUM (°F) _____</p> <p>15 MINIMUM (°F) _____</p> <p>16 UNUSUAL CONDITIONS:</p> <p>17 <input type="radio"/> DUST <input type="radio"/> FUMES <input type="radio"/> SALT ATMOSPHERE</p> <p>18 <input type="radio"/> OTHER _____</p> <p>19 _____</p> <p>20 UTILITY CONDITIONS:</p> <table style="width:100%; border: none;"> <tr> <td style="width: 20%;"></td> <td style="width: 20%; text-align: center;">DRIVERS</td> <td style="width: 20%; text-align: center;">HEATING</td> <td style="width: 20%;"></td> </tr> <tr> <td>21 INLET MIN.</td> <td>_____ (psig) _____ (°F)</td> <td>_____ (psig) _____ (°F)</td> <td></td> </tr> <tr> <td>23 NORM</td> <td>_____ (psig) _____ (°F)</td> <td>_____ (psig) _____ (°F)</td> <td></td> </tr> <tr> <td>24 MAX.</td> <td>_____ (psig) _____ (°F)</td> <td>_____ (psig) _____ (°F)</td> <td></td> </tr> <tr> <td>25 EXHAUST MIN.</td> <td>_____ (psig) _____ (°F)</td> <td>_____ (psig) _____ (°F)</td> <td></td> </tr> <tr> <td>26 NORM</td> <td>_____ (psig) _____ (°F)</td> <td>_____ (psig) _____ (°F)</td> <td></td> </tr> <tr> <td>27 MAX.</td> <td>_____ (psig) _____ (°F)</td> <td>_____ (psig) _____ (°F)</td> <td></td> </tr> </table> <p>28 ELECTRICITY:</p> <table style="width:100%; border: none;"> <tr> <td style="width: 20%;"></td> <td style="width: 20%; text-align: center;">DRIVERS</td> <td style="width: 20%; text-align: center;">HEATING</td> <td style="width: 20%; text-align: center;">CONTROL</td> <td style="width: 20%; text-align: center;">SHUT-DOWN</td> </tr> <tr> <td>29 VOLTAGE</td> <td>_____</td> <td>_____</td> <td>_____</td> <td>_____</td> </tr> <tr> <td>31 HERTZ</td> <td>_____</td> <td>_____</td> <td>_____</td> <td>_____</td> </tr> <tr> <td>32 PHASE</td> <td>_____</td> <td>_____</td> <td>_____</td> <td>_____</td> </tr> </table> <p>33 COOLING WATER</p> <p>34 TEMP. INLET _____ (°F) MAX. RETURN _____ (°F)</p> <p>35 PRESS. NORM _____ (psig) DESIGN _____ (psig)</p> <p>36 MIN. RETURN _____ (psig) MAX. ALLOW D P _____ (psia)</p> <p>37 WATER SOURCE _____</p> <p>38 INSTRUMENT AIR:</p> <p>39 MAX PRESS _____ (psig) MIN. _____ (psig)</p> <p>40 <input type="checkbox"/> TOTAL UTILITY CONSUMPTION:</p> <p>41 COOLING WATER _____ (gph)</p> <p>42 STEAM, NORMAL _____ (lb/hr)</p> <p>43 STEAM, MAX _____ (lb/hr)</p> <p>44 INSTRUMENT AIR _____ (scfm)</p> <p>45 POWER (DRIVER) _____ (HP)</p> <p>46 POWER (AUXILIARIES): _____ (HP)</p> <p>47 _____</p> <p>48 BASEPLATE (7.4)</p> <p>49 <input type="radio"/> COMMON (UNDER PUMP & DRIVER) <input type="radio"/> OTHER</p> <p>50 <input type="radio"/> DECKED WITH NON-SKID DECK PLATE (7.4.12) <input type="radio"/> OPEN CONSTR.</p> <p>51 <input type="radio"/> DRIP RIM <input type="radio"/> WITH OPEN DRAIN <input type="radio"/> SUBPLATE</p> <p>52 <input type="radio"/> HORIZONTAL ADJUSTING SCREWS FOR EQUIPMENT (7.4.4)</p> <p>53 <input type="radio"/> EPOXY GROUT/EPOXY PRIMER</p>		DRIVERS	HEATING		21 INLET MIN.	_____ (psig) _____ (°F)	_____ (psig) _____ (°F)		23 NORM	_____ (psig) _____ (°F)	_____ (psig) _____ (°F)		24 MAX.	_____ (psig) _____ (°F)	_____ (psig) _____ (°F)		25 EXHAUST MIN.	_____ (psig) _____ (°F)	_____ (psig) _____ (°F)		26 NORM	_____ (psig) _____ (°F)	_____ (psig) _____ (°F)		27 MAX.	_____ (psig) _____ (°F)	_____ (psig) _____ (°F)			DRIVERS	HEATING	CONTROL	SHUT-DOWN	29 VOLTAGE	_____	_____	_____	_____	31 HERTZ	_____	_____	_____	_____	32 PHASE	_____	_____	_____	_____	<p><input type="checkbox"/> CONNECTIONS:</p> <table border="1" style="width: 100%; border-collapse: collapse;"> <thead> <tr> <th>SIZE</th> <th>ANSI RATING</th> <th>FACING</th> <th>POSITION</th> </tr> </thead> <tbody> <tr> <td></td> <td></td> <td></td> <td></td> </tr> <tr> <td></td> <td></td> <td></td> <td></td> </tr> <tr> <td></td> <td></td> <td></td> <td></td> </tr> <tr> <td></td> <td></td> <td></td> <td></td> </tr> <tr> <td></td> <td></td> <td></td> <td></td> </tr> <tr> <td></td> <td></td> <td></td> <td></td> </tr> <tr> <td></td> <td></td> <td></td> <td></td> </tr> <tr> <td></td> <td></td> <td></td> <td></td> </tr> <tr> <td></td> <td></td> <td></td> <td></td> </tr> </tbody> </table> <p>CASING (4.3)</p> <p>INLET _____</p> <p>DISCHARGE _____</p> <p>SKID INLET _____</p> <p>SKID OUTLET _____</p> <p><input type="checkbox"/> OTHER CONNECTIONS:</p> <table border="1" style="width: 100%; border-collapse: collapse;"> <thead> <tr> <th>SERVICE</th> <th>NO</th> <th>SIZE</th> <th>TYPE / ANSI RATING</th> </tr> </thead> <tbody> <tr> <td>LUBE OIL INLET</td> <td></td> <td></td> <td></td> </tr> <tr> <td>LUBE OIL OUTLET</td> <td></td> <td></td> <td></td> </tr> <tr> <td>SEAL OIL INLET</td> <td></td> <td></td> <td></td> </tr> <tr> <td>SEAL OIL OUTLET</td> <td></td> <td></td> <td></td> </tr> <tr> <td>CASING DRAINS</td> <td></td> <td></td> <td></td> </tr> <tr> <td>VENTS</td> <td></td> <td></td> <td></td> </tr> <tr> <td>COOLING WATER</td> <td></td> <td></td> <td></td> </tr> <tr> <td>CASE PRESSURE</td> <td></td> <td></td> <td></td> </tr> <tr> <td>TEMPERATURE</td> <td></td> <td></td> <td></td> </tr> <tr> <td>PURGE FOR:</td> <td></td> <td></td> <td></td> </tr> </tbody> </table> <p>DRIVER TYPE</p> <p><input type="radio"/> INDUCTION MOTOR <input type="radio"/> STEAM TURBINE <input type="radio"/> GEAR <input type="radio"/> OTHER</p> <p>DRIVE MECHANISM</p> <p><input type="radio"/> DIRECT-COUPLED <input type="radio"/> ASD <input type="radio"/> OTHER _____</p> <p><input checked="" type="checkbox"/> COUPLING MANUFACTURER _____</p> <p><input checked="" type="checkbox"/> COUPLING TYPE _____</p> <p><input type="checkbox"/> RATING (MAX TORQUE) _____ <input checked="" type="checkbox"/> MODEL _____</p> <p><input checked="" type="checkbox"/> SPACER LENGTH _____ (IN) <input checked="" type="checkbox"/> S.F. _____</p> <p><input type="radio"/> COUPLING BALANCED <input type="radio"/> MANF STD <input type="radio"/> ISO 1940-1 G6.3 (7.2.3)</p> <p><input type="radio"/> COUPLING PER API 671 (7.2.4)</p> <p><input type="radio"/> COUPLING HUB ATTACHMENT <input type="radio"/> TAPERED</p> <p><input type="radio"/> STRAIGHT <input type="radio"/> KEYED <input type="radio"/> HYDRAULIC FIT</p> <p>COUPLING GUARD TYPE</p> <p><input type="radio"/> STEEL <input type="radio"/> BRASS <input type="radio"/> NON-METALLIC <input type="radio"/> OTHER</p> <p><input checked="" type="checkbox"/> NON SPARK COUPLING GUARD (7.2.15c) _____</p> <p><input type="radio"/> MOTOR DRIVER (7.1) (SEE MOTOR DATA SHEET)</p> <p><input type="radio"/> IEEE 841 <input type="radio"/> API 541 <input type="radio"/> API 546 <input type="radio"/> OTHER</p> <p><input type="radio"/> ASD SUPPLIED BY <input type="radio"/> PURCHASER <input type="radio"/> MOTOR SUPPLIER</p> <p><input type="checkbox"/> MANUFACTURER _____ <input type="checkbox"/> TYPE _____</p> <p><input type="checkbox"/> FRAME _____ <input checked="" type="checkbox"/> ENCLOSURE _____</p> <p><input checked="" type="checkbox"/> HORIZONTAL <input checked="" type="checkbox"/> VERTICAL</p> <p><input type="checkbox"/> (HP) _____ (rpm) _____</p> <p><input type="radio"/> VOLTS _____ PHASE _____ HERTZ _____ SERVICE FACTOR _____</p> <p><input type="radio"/> VARIABLE SPEED RANGE _____ (rpm)</p> <p><input type="radio"/> MINIMUM STARTING VOLTAGE (7.1.2.2) _____</p> <p><input checked="" type="checkbox"/> INSULATION _____ <input type="radio"/> TEMP. RISE _____</p> <p><input checked="" type="checkbox"/> FULL LOAD AMPS _____</p> <p><input checked="" type="checkbox"/> LOCKED ROTOR AMPS _____</p> <p><input checked="" type="checkbox"/> STARTING METHOD _____</p> <p><input checked="" type="checkbox"/> LUBE _____</p> <p>DRIVER BEARINGS (TYPE/NUMBER):</p> <p><input type="checkbox"/> RADIAL _____ / _____</p> <p><input type="checkbox"/> THRUST _____ / _____</p>	SIZE	ANSI RATING	FACING	POSITION																																					SERVICE	NO	SIZE	TYPE / ANSI RATING	LUBE OIL INLET				LUBE OIL OUTLET				SEAL OIL INLET				SEAL OIL OUTLET				CASING DRAINS				VENTS				COOLING WATER				CASE PRESSURE				TEMPERATURE				PURGE FOR:			
	DRIVERS	HEATING																																																																																																																																			
21 INLET MIN.	_____ (psig) _____ (°F)	_____ (psig) _____ (°F)																																																																																																																																			
23 NORM	_____ (psig) _____ (°F)	_____ (psig) _____ (°F)																																																																																																																																			
24 MAX.	_____ (psig) _____ (°F)	_____ (psig) _____ (°F)																																																																																																																																			
25 EXHAUST MIN.	_____ (psig) _____ (°F)	_____ (psig) _____ (°F)																																																																																																																																			
26 NORM	_____ (psig) _____ (°F)	_____ (psig) _____ (°F)																																																																																																																																			
27 MAX.	_____ (psig) _____ (°F)	_____ (psig) _____ (°F)																																																																																																																																			
	DRIVERS	HEATING	CONTROL	SHUT-DOWN																																																																																																																																	
29 VOLTAGE	_____	_____	_____	_____																																																																																																																																	
31 HERTZ	_____	_____	_____	_____																																																																																																																																	
32 PHASE	_____	_____	_____	_____																																																																																																																																	
SIZE	ANSI RATING	FACING	POSITION																																																																																																																																		
SERVICE	NO	SIZE	TYPE / ANSI RATING																																																																																																																																		
LUBE OIL INLET																																																																																																																																					
LUBE OIL OUTLET																																																																																																																																					
SEAL OIL INLET																																																																																																																																					
SEAL OIL OUTLET																																																																																																																																					
CASING DRAINS																																																																																																																																					
VENTS																																																																																																																																					
COOLING WATER																																																																																																																																					
CASE PRESSURE																																																																																																																																					
TEMPERATURE																																																																																																																																					
PURGE FOR:																																																																																																																																					

54	REMARKS _____
55	

DOCUMENT NUMBER: _____

CLIENT DOCUMENT NUMBER: _____

		0	1	2	3	4
	MULTIPHASE PUMP DATA SHEET (API 676 3rd Ed.) U.S. CUSTOMARY	DATE				
		BY				
		REV/APPR				
		JOB NO. _____	ITEM NO. _____			
		PAGE 3 OF 5	REQ'N NO. _____			
1	<input type="checkbox"/> MIN DESIGN METAL TEMP _____ (°F)	REMARKS _____				
2	<input type="checkbox"/> CASING:					
3	MATERIAL (6.13) _____					
4	<input type="checkbox"/> MAX. ALLOWABLE CASING PRESS. (6.3.1) _____ (psig)					
5	RELIEF VALVE SETTING (6.3.2) _____ (psig)					
6	MARGIN FOR ACCUMULATION _____ (psig)					
7	HYDRO PRESS. _____ (psig)					
8	MAX. ALLOW. TEMP. _____ (°F) MIN. OPER. TEMP. _____ (°F)					
9	COOLING / HEATING JACKET <input type="checkbox"/> YES <input type="checkbox"/> NO (6.3.6)					
10	<input type="checkbox"/> LINER					
11	LINER MATERIAL (6.13) _____					
12	HARD COATING MATERIAL _____					
13	<input type="checkbox"/> BEARING HOUSING MATERIAL					
14	<input checked="" type="checkbox"/> BEARING HOUSING COOLING _____					
15	<input type="checkbox"/> ROTORS: (6.8.1)					
16	DIAMETER (in) _____					
17	EROSION HARD COATING _____					
18	TYPE FABRICATION _____					
19	MATERIAL (6.13) _____					
20	BRINELL HARDNESS. MAX. _____ MIN. _____					
21	ROTOR LENGTH TO DIAMETER RATIO (L/D) _____					
22	ROTOR CLEARANCE (in) _____					
23	MAX. DEFLECTION (in) _____					
24	NON-CONTACT DESIGN _____					
25	<input type="checkbox"/> SHAFT:					
26	MATERIAL (6.13) _____					
27	DIA @ ROTORS (in) _____ DIA @ COUPLING (in) _____					
28	SHAFT END. <input type="checkbox"/> TAPERED <input type="checkbox"/> CYLINDRICAL (7.2.9)					
29	<input type="checkbox"/> TIMING GEARS: (6.8.2)					
30	<input checked="" type="checkbox"/> AGMA 11 QUALITY <input type="checkbox"/> OTHER QUALITY _____					
31	PITCH LINE DIAMETER (in) _____ TYPE _____					
32	MATERIAL _____					
33	BEARINGS (TYPE/NUMBER):					
34	<input type="checkbox"/> RADIAL _____ / _____					
35	<input type="checkbox"/> THRUST _____ / _____					
36	<input checked="" type="checkbox"/> SHAFT SEALS: (6.9) <input type="checkbox"/> Per API 682 data sheet					
37	<input type="checkbox"/> Seal Code _____ <input type="checkbox"/> Flush Plan _____					
38	<input type="checkbox"/> INNER SEAL LEAK GUARANTEE (gal/day/seal) _____					
39	<input type="checkbox"/> SEAL OIL SYSTEMS (plan 54) <input type="checkbox"/> Per API 614 (Chapter 3)					
40	BEARING TEMPERATURE DETECTORS:					
41	<input type="checkbox"/> AF BEARING OUTER RACE <input type="checkbox"/> OTHER _____					
42	<input type="checkbox"/> TC TYPE _____ <input type="checkbox"/> ORTD TYPE _____					
43	VIBRATION DETECTORS:					
44	<input type="checkbox"/> IN ACCORDANCE WITH: API 670					
45	<input type="checkbox"/> OTHER (SPECIFY) _____					
46	<input type="checkbox"/> TYPE _____ <input checked="" type="checkbox"/> MODEL _____					
47	<input type="checkbox"/> MFR. _____					
48	<input type="checkbox"/> NO. AT EACH BEARING _____ TOTAL NO. _____					
49	<input type="checkbox"/> MONITOR SUPPLIED BY _____					
50	<input type="checkbox"/> LOCATION _____ ENCLOSURE _____					
51	<input type="checkbox"/> MFR. _____ <input type="checkbox"/> MODEL _____					
52	<input type="checkbox"/> SCALE RANGE _____ <input type="checkbox"/> ALARM. <input type="checkbox"/> SET @ _____ MILS					

52 SHUTDN: SET @ ___ MILS TIME DLY. ___ SEC

53 PHASE REFERENCE TRANSDUCER

DOCUMENT NUMBER: _____
 CLIENT DOCUMENT NUMBER: _____

MULTIPHASE PUMP DATA SHEET (API 676 3rd Ed.) U.S. CUSTOMARY	REVISION	0	1	2	3	4
	DATE					
	BY					
	REVI/APPR					
	JOB NO.	_____				
	PAGE	4	OF	5	REQ'N NO.	_____

1 VENDOR MUST FURNISH ALL PERTINENT DATA FOR THIS SPECIFICATION SHEET BEFORE RETURNING.

2 ITEM NO. _____ SERVICE _____ JOB NO. _____

3 MANUFACTURER _____

4 LOCAL CONTROL PANEL:

5 FURNISHED BY: SUPPLIER PURCHASER OTHERS _____

6 FREE STANDING WEATHERPROOF TOTALLY ENCLOSED EXTRA CUTOUTS

7 VIBRATION ISOLATORS STRIP HEATERS PURGE CONNECTIONS

8 ANNUNCIATOR: FURNISHED BY: VENDOR PURCHASER OTHERS _____

9 ANNUNCIATOR LOCATED ON LOCAL PANEL MAIN CONTROL BOARD

10 CUSTOMER CONNECTIONS BROUGHT OUT TO TERMINAL BOXES BY VENDOR

11 INSTRUMENT SUPPLIERS:

12 <input type="radio"/> PRESSURE GAUGES:	MFR. _____	SIZE & TYPE: _____
13 <input type="radio"/> TEMPERATURE GAUGES:	MFR. _____	SIZE & TYPE: _____
14 <input type="radio"/> LEVEL GAUGES:	MFR. _____	SIZE & TYPE: _____
15 <input type="radio"/> DIFF. PRESSURE GAUGES:	MFR. _____	SIZE & TYPE: _____
16 <input type="radio"/> PRESSURE TRANSMITTERS:	MFR. _____	SIZE & TYPE: _____
17 <input type="radio"/> DIFF. PRESSURE TRANSMITTERS:	MFR. _____	SIZE & TYPE: _____
18 <input type="radio"/> TEMPERATURE TRANSMITTERS:	MFR. _____	SIZE & TYPE: _____
19 <input type="radio"/> LEVEL SWITCHES:	MFR. _____	SIZE & TYPE: _____
20 <input type="radio"/> CONTROL VALVES:	MFR. _____	SIZE & TYPE: _____
21 <input type="radio"/> PRESSURE LIMITING VALVES: (7.5)	MFR. _____	SIZE & TYPE: _____
22 <input type="radio"/> SIGHT FLOW INDICATORS:	MFR. _____	SIZE & TYPE: _____
23 <input type="radio"/> FLOW INDICATOR:	MFR. _____	SIZE & TYPE: _____
24 <input type="radio"/> VIBRATION EQUIPMENT:	MFR. _____	SIZE & TYPE: _____
25 <input type="radio"/> SOLENOID VALVES	MFR. _____	SIZE & TYPE: _____
26 <input type="radio"/> ANNUNCIATOR:	MFR. _____	MODEL & NO. POINTS _____
27 <input type="radio"/> OTHER	MFR. _____	SIZE & TYPE: _____

28 PRESSURE GAUGE REQUIREMENTS NOTE: SUPPLIED BY VENDOR SUPPLIED BY PURCHASER

FUNCTION	LOCALLY MOUNTED		LOCAL PANEL		FUNCTION	LOCALLY MOUNTED		LOCAL PANEL	
	<input type="checkbox"/>	<input type="checkbox"/>	<input type="checkbox"/>	<input type="checkbox"/>		<input type="checkbox"/>	<input type="checkbox"/>	<input type="checkbox"/>	<input type="checkbox"/>
31 PUMP SUCTION	<input type="checkbox"/>	<input type="checkbox"/>	<input type="checkbox"/>	<input type="checkbox"/>	SEAL OIL PUMP DISCHARGE	<input type="checkbox"/>	<input type="checkbox"/>	<input type="checkbox"/>	<input type="checkbox"/>
32 PUMP DISCHARGE	<input type="checkbox"/>	<input type="checkbox"/>	<input type="checkbox"/>	<input type="checkbox"/>	SEAL OIL FILTER Δ P	<input type="checkbox"/>	<input type="checkbox"/>	<input type="checkbox"/>	<input type="checkbox"/>
33 LUBE OIL PUMP DISCHARGE	<input type="checkbox"/>	<input type="checkbox"/>	<input type="checkbox"/>	<input type="checkbox"/>	SEAL OIL SUPPLY	<input type="checkbox"/>	<input type="checkbox"/>	<input type="checkbox"/>	<input type="checkbox"/>
34 LUBE OIL FILTER Δ P	<input type="checkbox"/>	<input type="checkbox"/>	<input type="checkbox"/>	<input type="checkbox"/>	SEAL OIL DIFFERENTIAL	<input type="checkbox"/>	<input type="checkbox"/>	<input type="checkbox"/>	<input type="checkbox"/>
35 LUBE OIL SUPPLY	<input type="checkbox"/>	<input type="checkbox"/>	<input type="checkbox"/>	<input type="checkbox"/>	OTHER	<input type="checkbox"/>	<input type="checkbox"/>	<input type="checkbox"/>	<input type="checkbox"/>

36 TEMPERATURE GAUGE REQUIREMENTS:

FUNCTION	LOCALLY MOUNTED		LOCAL PANEL		FUNCTION	LOCALLY MOUNTED		LOCAL PANEL	
	<input type="checkbox"/>	<input type="checkbox"/>	<input type="checkbox"/>	<input type="checkbox"/>		<input type="checkbox"/>	<input type="checkbox"/>	<input type="checkbox"/>	<input type="checkbox"/>
37 LUBE DRAIN @ EA. BRG.	<input type="checkbox"/>	<input type="checkbox"/>	<input type="checkbox"/>	<input type="checkbox"/>	COOLER OIL INLET & OUTLET	<input type="checkbox"/>	<input type="checkbox"/>	<input type="checkbox"/>	<input type="checkbox"/>
38 PUMP RADIAL BEARING	<input type="checkbox"/>	<input type="checkbox"/>	<input type="checkbox"/>	<input type="checkbox"/>	LUBE OIL RESERVOIR	<input type="checkbox"/>	<input type="checkbox"/>	<input type="checkbox"/>	<input type="checkbox"/>
39 PUMP THRUST BEARING	<input type="checkbox"/>	<input type="checkbox"/>	<input type="checkbox"/>	<input type="checkbox"/>	SEAL OIL RESERVOIR	<input type="checkbox"/>	<input type="checkbox"/>	<input type="checkbox"/>	<input type="checkbox"/>
40 SEAL OIL OUTLET	<input type="checkbox"/>	<input type="checkbox"/>	<input type="checkbox"/>	<input type="checkbox"/>	PUMP SUCTION	<input type="checkbox"/>	<input type="checkbox"/>	<input type="checkbox"/>	<input type="checkbox"/>
41 OTHER	<input type="checkbox"/>	<input type="checkbox"/>	<input type="checkbox"/>	<input type="checkbox"/>	PUMP DISCHARGE	<input type="checkbox"/>	<input type="checkbox"/>	<input type="checkbox"/>	<input type="checkbox"/>

44 SWITCH CLOSURES:

45 ALARM CONTACTS SHALL: OPEN CLOSE TO SOUND ALARM AND BE NORMALLY ENERGIZED DE-ENERGIZED

46 SHUTDOWN CONTACTS SHALL: OPEN CLOSE TO TRIP AND BE NORMALLY ENERGIZED DE-ENERGIZED

47 NOTE: NORMAL CONDITION IS WHEN MPP IS IN OPERATION.

DOCUMENT NUMBER: _____
 CLIENT DOCUMENT NUMBER: _____

MULTIPHASE PUMP DATA SHEET (API 676 3rd Ed.) U.S. CUSTOMARY					REVISION	0	1	2	3	4
					DATE					
					BY					
					REV/APPR					
					JOB NO.	ITEM NO.				
					PAGE	5	OF	5	REQ'N NO.	

VENDOR MUST FURNISH ALL PERTINENT DATA FOR THIS SPECIFICATION SHEET BEFORE RETURNING.

ITEM NO. _____ SERVICE _____ JOB NO. _____

MANUFACTURER _____

1	ALARM & SHUTDOWN:	ALARM	TRIP	2	FUNCTION	PRE-ALARM	TRIP
3	LOW LUBE OIL PRESSURE	_____	_____		PUMP VIBRATION	_____	_____
4	<input type="checkbox"/> <input type="radio"/> HI LUBE OIL FILTER Δ P	_____	_____		<input type="checkbox"/> <input type="radio"/> HI SEAL OIL OUTLET TEMP. (COOLER)	_____	_____
5	<input type="checkbox"/> <input type="radio"/> HI SEAL OIL FILTER Δ P	_____	_____		<input type="checkbox"/> <input type="radio"/> PUMP HI DISCH. TEMP.	_____	_____
6	<input type="checkbox"/> <input type="radio"/> LOW LUBE OIL RESERVOIR LEV.	_____	_____		<input type="checkbox"/> <input type="radio"/> HI LUBE OIL OUTLET TEMP. (COOLER)	_____	_____
7	<input type="checkbox"/> <input type="radio"/> LOW SEAL OIL RESERVOIR LEV.	_____	_____		<input type="checkbox"/> <input type="radio"/> DRIVER VIBRATION	_____	_____
8	<input type="checkbox"/> <input type="radio"/> HI SEAL OIL LEVEL	_____	_____		<input type="checkbox"/> <input type="radio"/> DRIVER SHUTDOWN	_____	_____
9	<input type="checkbox"/> <input type="radio"/> LOW SEAL OIL LEVEL	_____	_____		<input type="checkbox"/> <input type="radio"/> HI PUMP BRG. TEMP.	_____	_____
10	<input type="checkbox"/> <input type="radio"/> HI SEAL OIL PRESSURE	_____	_____		<input type="checkbox"/> <input type="radio"/> HI DRIVER BRG. TEMP.	_____	_____
11	<input type="checkbox"/> <input type="radio"/> LOW SEAL OIL PRESSURE	_____	_____		<input type="checkbox"/> <input type="radio"/> PUMP D P	_____	_____
12	<input type="checkbox"/> <input type="radio"/> AUX. SEAL OIL PUMP START	_____	_____		<input type="checkbox"/> <input type="radio"/> OTHER _____	_____	_____
13	<input type="checkbox"/> <input type="radio"/> AUX. LUBE OIL PUMP START	_____	_____		<input type="checkbox"/> <input type="radio"/> OTHER _____	_____	_____
14							

15 MISCELLANEOUS INSTRUMENTATION:

16 DRIVER START/STOP LOCAL PANEL REMOTE PANEL

17 SIGHT FLOW INDICATORS, EACH BEARING HOUSING SIGHT FLOW INDICATORS, EACH SEAL OIL RETURN LINE

18 VIBRATION DETECTORS VIBRATION AND BEARING TEMPERATURE MONITORS

19 VIBRATION READOUT LOCATED ON: LOCAL PANEL REMOTE PANEL

20 LEVEL GAUGES, LUBE AND/OR SEAL OIL RESERVOIR

21 OTHER _____

22 MISCELLANEOUS:

23 INSTRUMENT TAGGING REQUIRED.

24 ALARM AND SHUTDOWN TRANSMITTERS SHALL BE SEPARATE.

25 PURCHASERS ELECTRICAL AND INSTRUMENT CONNECTIONS WITHIN THE CONFINES OF THE BASEPLATE AND CONSOLE SHALL BE:

26 BROUGHT OUT TO TERMINAL BOXES. MADE DIRECTLY BY THE PURCHASER.

27 COMMENTS REGARDING INSTRUMENTATION: _____

28

29	30 PUMP SHOP INSPECTION AND TESTS:			30	MISCELLANEOUS:
	REQ'D	WITNESS	OBSERVE		
31	SHOP INSPECTION (8.1)	<input type="radio"/>	<input type="radio"/>	<input type="radio"/>	<input type="checkbox"/> RECOMMENDED STRAIGHT PIPE DIA. BEFORE SUCTION _____
32	HYDROSTATIC (8.3.2)	<input type="radio"/>	<input type="radio"/>	<input type="radio"/>	<input type="checkbox"/> VENDOR'S REVIEW & COMMENTS ON PURCHASER'S PIPING & FOUNDATION (7.8.2.d NOTE 4)
33	MECHANICAL RUN (8.3.5.1)	<input type="radio"/>	<input type="radio"/>	<input type="radio"/>	<input type="checkbox"/> VENDOR REPRESENTATIVE OBSERVATION AT THE SITE
34	MECHANICAL RUN SPARE ROTORS	<input type="radio"/>	<input type="radio"/>	<input type="radio"/>	<input type="checkbox"/> SPARE PARTS TO BE SUPPLIED
35	CASING LEAK TEST	<input type="radio"/>	<input type="radio"/>	<input type="radio"/>	<input type="checkbox"/> ROTOR ASSEMBLY <input type="checkbox"/> BEARINGS <input type="checkbox"/> SEALS
36	PERFORMANCE TEST (GAS) (LIQUID)	<input type="radio"/>	<input type="radio"/>	<input type="radio"/>	<input type="checkbox"/> 2 YEARS SUPPLY <input type="checkbox"/> GASKETS, O-RINGS
37	COMPLETE UNIT TEST (8.3.7.2)	<input type="radio"/>	<input type="radio"/>	<input type="radio"/>	<input type="checkbox"/> START-UP/COMMISSIONING <input type="checkbox"/> OTHER _____
38	USE SHOP LUBE & SEAL SYSTEM	<input type="radio"/>	<input type="radio"/>	<input type="radio"/>	<input type="checkbox"/> WEIGHTS: (lb)
39	USE CONTRACT LUBE & SEAL SYSTEM	<input type="radio"/>	<input type="radio"/>	<input type="radio"/>	PUMP _____ DRIVER _____ BASEPLATE _____
40	USE CONTRACT VIBRATION PROBES, ETC.	<input type="radio"/>	<input type="radio"/>	<input type="radio"/>	ROTORS: PUMP _____ DRIVER _____
41	USE JOB BEARING VIBRATION AND TEMPERATURE	<input type="radio"/>	<input type="radio"/>	<input type="radio"/>	LUBE OIL CONSOLE _____
42	TRANSDUCERS & MONITORS	<input type="radio"/>	<input type="radio"/>	<input type="radio"/>	SEAL OIL CONSOLE _____
43	PRESSURE PUMP TO FULL OPER. PRESS.	<input type="radio"/>	<input type="radio"/>	<input type="radio"/>	MAX. FOR MAINTENANCE (IDENTIFY) _____
44	DISASSEMBLE-REASSEMBLE PUMP	<input type="radio"/>	<input type="radio"/>	<input type="radio"/>	TOTAL SHIPPING WEIGHT _____
45	AFTER TEST	<input type="radio"/>	<input type="radio"/>	<input type="radio"/>	
46	INSPECT BEARINGS AFTER TEST	<input type="radio"/>	<input type="radio"/>	<input type="radio"/>	<input type="checkbox"/> SPACE REQUIREMENTS: (in)
47	SOUND-LEVEL TEST (8.3.7.3)	<input type="radio"/>	<input type="radio"/>	<input type="radio"/>	COMPLETE UNIT L _____ W _____ H _____
48	AUX. EQUIPMENT (8.3.4.3)	<input type="radio"/>	<input type="radio"/>	<input type="radio"/>	LUBE OIL CONSOLE L _____ W _____ H _____
49	FULL-LOAD STRING TEST	<input type="radio"/>	<input type="radio"/>	<input type="radio"/>	SEAL OIL CONSOLE L _____ W _____ H _____
50	GAS SLUG TEST	<input type="radio"/>	<input type="radio"/>	<input type="radio"/>	
51		<input type="radio"/>	<input type="radio"/>	<input type="radio"/>	
52		<input type="radio"/>	<input type="radio"/>	<input type="radio"/>	
53		<input type="radio"/>	<input type="radio"/>	<input type="radio"/>	

ROTARY PUMP (API 676-3RD)

JOB NO. _____ ITEM NO.(S) _____
 REQ / SPEC NO. _____ / _____
 PURCH ORDER NO. _____ DATE _____
 INQUIRY NO. _____ BY _____
 REVISION NO. _____ DATE: _____

PRESSURE DESIGN CODES
 WELDING REQUIREMENTS
 PURCHASER DEFINED MATERIAL INSPECTIONS

1 APPLICABLE TO: PROPOSALS PURCHASE AS BUILT
 2 FOR _____ UNIT _____
 3 SITE _____ SERVICE _____
 4 NO. REQ _____ PUMP SIZE _____ TYPE _____ NO. STAGES _____
 5 MANUFACTURER _____ MODEL _____ SERIAL NO. _____

6 NOTES: INFORMATION BELOW TO BE COMPLETED: BY PURCHASER BY MANUFACTURER BY MANUFACTURER OR PURCHASER
 7 PRESSURE VESSEL DESIGN CODE REFERENCES.

8 THESE REFERENCES MUST BE LISTED BY THE MANUFACTURER

12 WELDING AND REPAIRS (6.13.5 & 6.13.1)

13 THESE REFERENCES MUST BE LISTED BY THE PURCHASER. (DEFAULT TO TABLE 5 IF NO PURCHASER PREFERENCE IS STATED)

14 ALTERNATE WELDING CODES AND STANDARDS (6.13.5.1) Vendor defined - Purchaser approved

15 Welding Requirement (Applicable Code or Standard)	Purchaser defined	Default per Table 5
16 Welder/operator qualification	<input type="radio"/>	<input type="radio"/>
17 Welding procedure qualification	<input type="radio"/>	<input type="radio"/>
18 Non-pressure retaining structural welding such as baseplates or supports	<input type="radio"/>	<input type="radio"/>
19 Magnetic Particle or Liquid Penetrant examination of plate edges	<input type="radio"/>	<input type="radio"/>
20 Postweld heat treatment (user specified in remarks below)	<input type="radio"/>	<input type="radio"/>
21 Postweld heat treatment of casing fabrication welds	<input type="radio"/>	<input type="radio"/>

22 WELDING APPROVALS:
 23 Submit Weld Procedures for approval
 24 Submit Pressure Boundary Weld Maps for approval on major weld repairs at pump mfr.

25 MATERIAL AND OTHER INSPECTIONS (8.2.2.1.1)(8.2.3.1)

26 THESE REFERENCES MUST BE LISTED BY THE PURCHASER (DEFAULT TO TABLE 6 IF NO PURCHASER METHOD PREFERENCE IS STATED)

27 ALTERNATIVE MATERIAL INSPECTIONS AND ACCEPTANCE CRITERIA (SEE TABLE 6)

28 Type of inspection	Para.	List Methods (if not API 676 defaults)	Press Bdry. Fabs	Piping	Press. Bdry. Cstgs.	Witness
30 <input type="radio"/> MSS-SP55 Visual casting inspection	6.13.3.3				<input type="radio"/>	<input type="radio"/>
31 <input type="radio"/> Magnetic particle inspection at foundry	8.2.2.1.1		<input type="radio"/>		<input type="radio"/>	<input type="radio"/>
32 <input type="radio"/> Liquid penetrant inspection at foundry	8.2.2.1.1		<input type="radio"/>		<input type="radio"/>	<input type="radio"/>
33 <input type="radio"/> RT critical areas casing casting at foundry	8.2.2.1.1		<input type="radio"/>		<input type="radio"/>	<input type="radio"/>
34 <input type="radio"/> Magnetic particle insp. - finished machined	8.2.2.1.1		<input type="radio"/>		<input type="radio"/>	<input type="radio"/>
35 <input type="radio"/> Liquid penetrant insp. - finished machined	8.2.2.1.1		<input type="radio"/>		<input type="radio"/>	<input type="radio"/>
36 <input type="radio"/> RT critical areas casing - near fin. mach'd.	8.2.2.1.1		<input type="radio"/>		<input type="radio"/>	<input type="radio"/>
37 <input type="radio"/> MT or PT of Fab'd PB* edges	6.13.5.3d		<input type="radio"/>			<input type="radio"/>
38 <input type="radio"/> MT or PT case attachment welds	8.2.2.1.1		<input type="radio"/>			<input type="radio"/>
39 <input type="radio"/> MT or PT rotor at foundry	8.2.2.1.1		<input type="radio"/>		<input type="radio"/>	<input type="radio"/>
40 <input type="radio"/> RT butt welds in aux. piping		<input type="radio"/> ASME B31.3 or 31.4 or 31.8		<input type="radio"/>		<input type="radio"/>
41 <input type="radio"/> MT or PT rotor - finished machined	8.2.2.1.1		<input type="radio"/>		<input type="radio"/>	<input type="radio"/>
42 <input type="radio"/> PMI all alloy pressure bndry components	8.2.4		<input type="radio"/>			<input type="radio"/>
43 <input type="radio"/> PMI alloy piping	8.2.4			<input type="radio"/>		<input type="radio"/>
44 <input type="radio"/> PMI alloy rotors	8.2.4			<input type="radio"/>		<input type="radio"/>
45 <input type="radio"/> Barstock with UT certificate for shaft	8.2.2.1.1		<input type="radio"/>	<input type="radio"/>		<input type="radio"/>
46 <input type="radio"/> Charpy Impact Test pressure bndry parts	6.13.6.5		<input type="radio"/>	<input type="radio"/>	<input type="radio"/>	<input type="radio"/>
47 <input type="radio"/> Casing caliper thickness check			<input type="radio"/>		<input type="radio"/>	<input type="radio"/>
48 <input type="radio"/> Rotor balance to ISO 1940 G2.5	6.8.1.9					<input type="radio"/>
49 <input type="radio"/> Hardness of parts, welds & HAZ						<input type="radio"/>
50 <input type="radio"/> Record Final assembly Clearances	8.2.1.1f					<input type="radio"/>

51 Material Test Reports 6.13.2.10: Casing* Rotor / Vanes Stators Shaft Bolting Aux Piping

52 HAZ is "heat affected zone" *Casing is any pressure containing or retaining part *PB is pressure boundary

ROTARY PUMP (API 676-3RD)

PAGE _____ OF _____

JOB NO. 0 ITEM NO.(S) 0 / 0

REQ / SPEC NO. 0

PURCH ORDER NO. 0 DATE 0

INQUIRY NO. 0 BY 0

REVISION NO. 0 DATE: 0

PRESSURE DESIGN CODES
 WELDING REQUIREMENTS
 PURCHASER DEFINED MATERIAL INSPECTIONS

1 APPLICABLE TO: PROPOSALS PURCHASE AS BUILT

2 FOR 0 UNIT 0

3 SITE 0 SERVICE 0

4 NO. REQ 0 PUMP SIZE 0 TYPE 0 NO. STAGES 0

5 MANUFACTURER 0 MODEL 0 SERIAL NO. 0

PAGE No. / LINE No.	REMARKS
8	
9	
10	
11	
12	
13	
14	
15	
16	
17	
18	
19	
20	
21	
22	
23	
24	
25	
26	
27	
28	
29	
30	
31	
32	
33	
34	
35	
36	
37	
38	
39	
40	
41	
42	
43	
44	
45	
46	
47	
48	
49	
50	
51	

Annex B (informative)

Factors Affecting Twin Screw Pump Wear Rate and Volumetric Efficiency

B.1 General

The purpose of this annex is to provide users with a general understanding of factors that may affect the volumetric efficiency of twin screw pumps. Pump design is often a compromise based on several factors present in the specific application.

Volumetric efficiency is the ratio of the pump rated point flow to the total theoretical displacement per unit time.

NOTE Volumetric efficiency is normally expressed as a percentage.

B.2 Major Factors

Twin screw pump wear rate and volumetric efficiency can be significantly affected over time by several competing factors. These are:

- a) particulate (quantity, hardness, shape, and size distribution);
- b) temperature and viscosity (pumped fluid viscosity);
- c) gas volume fraction (GVF);
- d) pump speed (regarding streams with little or no particulate); and
- e) differential pressure.

Items a) through c) are fluid characteristics, so it is important to understand the nature of the fluid being pumped.

B.2.1 Particulate

B.2.1.1 Quantity

The quantity of the particulate will determine if it needs to be considered as a design requirement. If there is little or no particulate, it does not need to be considered; however, if significant amounts of particulate are in the pumped stream, its effect on pump wear, and, in the long term, the pump's efficiency and ability to perform will be affected. It is recommended that unless a pumped stream has been proven to have no particulate, it should be assumed that particulate will be in the stream and will need to be addressed by the pump design.

B.2.1.2 Hardness

The hardness of the particulate also determines the extent of the design considerations required for the pump. Logically, the softer the particulate, the less of a design consideration it is. The normal hardness of the design materials for the pump screws and the case can handle soft particulate, either grinding it between the screw outer diameter (OD) and the bore inner diameter (ID) or between the screw OD and the adjacent screw's root diameter. Hard particulate not only opens these clearances, but the screw edges become rounded. These changes cause the pump to become inefficient by increasing the "slip" or backflow from the higher pressure downstream side of

the screw to the lower pressure upstream side of the screw, that is, across the screw lock. As these clearances open by erosion, the pump's ability to produce a required flowrate is diminished, the slip is increased, and the volumetric efficiency is reduced. If pump rotational speed is subsequently increased to regain the required flowrate, the rate of erosion is increased, and the cycle is repeated.

B.2.1.3 Shape

The same is true for the shape of the particulate. The sharper the edges of the particulate the more rapid is the erosion rate of these same clearances with the resulting increase in slip and loss of volumetric efficiency.

B.2.1.4 Size Distribution

The size distribution of the particulate plays a similar role. Particles that are relatively large compared to the clearances will tend to pass along the axis of the pump's shaft from suction to discharge, but they tend to cause the pump to bind. Experience has shown that it is best to prevent ingress of large particles into the pump by appropriate inlet protection, such as, inlet screens with differential pressure alarms. Those particles that are of the same order of magnitude as the pump's clearances tend to get wedged into the clearances producing wear, opening the clearances. In designing the pump, the clearances can be opened to allow the micro-sized particles to pass between the screw OD and the bore ID, reducing the wear. Since the clearance is increased, the total effective flowrate is decreased, and the amount of slip is increased, with a resulting decrease in the pump's efficiency.

B.2.1.5 Particulate Wear Mitigation

The pump's design can be modified to mitigate the effects of particulate by:

- a) changing the screw and case materials;
- b) designing the case to accept a hardened or coated replaceable liner;
- c) hardening the entire screw surface by processes such as boriding or nitriding;
- d) hardening the OD of the screws (the screw seals) by processes such as hard-facing;
- e) changing the screw profile (screw flank shape);
- f) increasing the number of screw seals (turns, closures, or screw locks) in the screw set;
- g) opening the clearances between the circumference of the screws (screw OD) and the case or case liner (bore ID) and between the circumference of the screws (screw OD) and the outside diameter of the adjacent screw's root diameter; and
- h) reducing the design operating speed for a given pump size.

A further explanation of some of the above follows.

B.2.1.5.1 Changing the Screw Profile (Flank Shape) [Item e) in B.2.1.5]

Changing the screw profile between the adjacent screw flanks to a gap appropriate to keep out the larger particulate, but pass the smaller-sized particulate, will reduce the erosion on the flanks. Though this helps to reduce erosion, the slip will be increased. An alternate method is to allow a pump to "wear-in" to achieve uniform clearances appropriate to the nature of the fluid pumped, but this wear-in volumetric efficiency should be

predetermined and shall be the one that the pump design is based upon. This method may also wear through any hard coating on the rotors.

B.2.1.5.2 Increasing the Number of Seals (Turns, Closures, or Screw Locks) [Item f) in B.2.1.5]

Increasing the number of seals (turns, closures, or screw locks) in the screw set, for the same total pressure differential across the pump flanges, reduces the differential pressure built across each screw seal. This reduces the velocity of the slippage over each screw seal from the high pressure to the low pressure side of each closure, and therefore reduces the erosion rate.

B.2.1.5.3 Opening the Clearances [Item g) in B.2.1.5]

Opening the clearances between the screw OD and the casing bore ID, and between the screw OD and the root diameter of the adjacent screw's shaft, reduces the velocity of the fluid that is slipping back within these clearance regions. If this fluid were to contain solid particulate, the effect of jetting erosion within the pumping internals could be reduced, since the carrying velocity of the liquid has been diminished. These increased clearances would also permit larger particles to travel more freely across these shaft land areas, without contributing to additional wear and subsequent further increase of the radial clearance between the screw OD and the casing bore ID. A design modification of this type would initially result in a lower volumetric efficiency for the pump, although overall the volumetric efficiency of the pump when conveying fluids with solid particulate may be more stable.

B.2.1.5.4 Reducing the Design Operating Speed [Item h) on the Previous List]

Erosion is related to velocity by a power of approximately 3.5 ($e \sim v^{3.5}$). So, for a given diameter screw the higher the initial pump speed, the higher the screw's circumferential or tip velocity, and the higher the built-in erosion rate. Of course, the higher the erosion rate, the more quickly the slip increases and more quickly the pump's volumetric efficiency is reduced. The resulting speed increase to overcome this increased slip and reduction of the pump's flow-rate results in an even higher screw tip velocity leading to more rapid erosion, which causes even more slip and further loss of efficiency. This cycle is continually repeated ever more frequently. Conversely, if the initial design speed of the pump is low (e.g. 900 rpm or 1200 rpm) for a given diameter screw the initial screw tip velocity is lowered, and the rate of erosion will then be lower than if the initial speed of the pump is 3600 rpm. While this means that for a certain flowrate, the pump will be larger and initially cost more, the pump's volumetric efficiency will be able to be maintained for a longer period of time. For a twin screw to maintain its volumetric efficiency, therefore, the lower the initial design speed and tip velocity, the lower the initial erosion rate, and the longer the design volumetric efficiency is able to be maintained.

B.2.2 Temperature and Viscosity

The pump design should be adjusted to compensate for maximum operating conditions. In order to handle high pumped fluid flowing temperatures [above 148 °C (above 300 °F)], the clearances shall be set appropriately depending on the materials of construction and the design to allow for thermal growth of the components. For example, the higher the temperature, the greater the clearances should be opened between the screw ODs and the bore ID. This increased clearance means that the pump will have increased slip until it is hot and cannot provide the rated flow until fully heated.

NOTE Take care not to change temperature quickly or flow hot fluid into a cold pump as rapid temperature change can cause dimensional distortion with severe consequences to the pump.

The apparent viscosity of the pumped fluid is an important design parameter. The higher the apparent fluid flowing viscosity the more the fluid seals the clearance between the screw OD and the bore ID. This fluid seal reduces the slip and thereby maintains the volumetric efficiency of the pump over time.

Also, the higher the viscosity, the more any contained particulate is coated by the fluid which then acts as a buffer around the particulate. The result is that the pump sustains less erosion as the particulate passes through it.

Existing data demonstrates that low viscosity fluids (for example gasoline or water), and low viscosity fluids containing GVF's of about 70 %, cause MPPs to lose volumetric efficiency as the pump's differential pressure is increased. This loss of volumetric efficiency with increasing differential pressure seems to be lessened the higher the GVF until the reduction is minimized at GVF's above 90 %.

B.2.3 Gas Volume Fraction (GVF)

Volumetric efficiency is often counter-intuitive if high GVF fluids are being pumped. Pressure is developed in the last lock of the pump. Volumetric efficiency remains relatively constant as the differential pressure increases. Pump wear from the particulate in the liquid phase may be seen at the OD-flank intersection of the screw. Sufficient liquid shall be maintained in the pump to maintain the seals in the pumping elements in order to maintain flow.

B.2.4 Pump Speed (Regarding Streams with Little or No Particulate)

Since the amount of slip is a constant at a given viscosity and pressure differential, the higher the pump speed the higher the calculated total amount of volume transferred and the higher the calculated volumetric efficiency.

B.2.5 Conclusions

Those items which negatively impact twin screw wear rate and volumetric efficiency are:

- a) streams containing high quantities of hard, sharp-edged, clearance-sized particulate,
- b) low viscosity fluid streams,
- c) high rotating speed (particulate laden),
- d) low rotating speed (clean),
- e) high clearance screw profiles (lower efficiency but with less potential for wear),
- f) a few number of screw seals (turns or closures), and
- g) high differential pressure.

Conversely, those items which positively impact wear rate and volumetric efficiency are:

- a) streams containing little or no particulate,
- b) high apparent viscosity fluid streams,
- c) low rotating speed (particulate laden),
- d) high rotating speed (clean),
- e) low clearance screw profiles (higher efficiency but with more potential for wear),
- f) many screw seals (turns or closures), and

g) low differential pressure.

Keep in mind that this annex is just meant to be an introduction to this complicated, many faceted subject.

Annex C (informative)

Inspector's Checklist

The levels indicated in Table C.1 may be characterized as follows:

- Level 1 is typically used for pumps in general services,
- Level 2 comprises performance and material requirements and is more stringent than Level 1,
- Level 3 items should be considered for pumps in critical services.

The required inspection shall be indicated in the first column as:

- C: Certification only,
- O: Observed inspection,
- W: Witnessed inspection.

Table C.1—Inspector's Checklist

Inspection Required C, O, or W	Item	API 676 Subsection Number	Date Inspected	Inspected by	Status
	Nozzle size, rating, and finish ^a	6.4.3, 6.4.4, 6.6, 9.3.2.1			
	Casing jackscrews	6.3.5			
	Baseplate requirements	7.4			
	Certified hydrostatic test	8.2.1.2, 8.3.2			
	Performance within tolerance (certified)	8.3.4, 8.3.6			
	NPSH within tolerance (certified)	8.3.7.1, 8.3.6			
	Vibration within tolerance	6.11			
	Rotation arrow ^a	6.14.2			
	Overall dimensions and connection locations ^a	9.2.2.1, 9.2.2.2, 9.3.2.1			
	Anchor bolt layout and size ^a	9.2.2.1, 9.2.2.2, 9.3.2.1			
	Shaft and keyway dimensions ^a	9.2.2.1, 9.2.2.2			
	Equipment feet pilot holes	9.2.2.1, 9.2.2.2			
	Relief valve characteristics	6.3.2, 7.5			
	Special tools	7.9			
	Motors and electrical components area classification	6.1.10, 7.1.1, 7.1.2, 7.6			
	Piping fabrication and installation	6.5, 6.13.5			
	Equipment nameplate data	6.14			
	Restrained motor rotor ^a	Sleeve bearing motor			
	Storage preservation instructions	8.4			
	Rust prevention	8.4.3.2 through 8.4.3.6, 8.4.3.9, 8.4.5			

Table C.1—Inspector's Checklist (Continued)

Inspection Required C, O, or W	Item	API 676 Subsection Number	Date Inspected	Inspected by	Status
	Painting	7.4.13, 8.4.3.1			
	Preparation for shipment	8.4			
	Shipping documents and tags	8.4.3.8			
	Level 2—Intermediate (Add to Level 1)				
	Copies of sub-vendor purchase order	9.1.3 Item a)			
	Material certification	6.13.2.10, 8.2.1.1 Item a)			
	NDT (components)	8.2.2			
	Hardness testing	6.13.2.13			
	Hydrostatic test witnessed	8.1, 8.2.1.2, 8.3.2			
	Building records (runouts, clearances)	6.8.1.5, 8.2.1.1 Item f)			
	Performance and NPSH tests witnessed	8.1, 8.3.4, 8.3.6, 8.3.7.1			
	Level 3—Special (Add to Levels 1 and 2)				
	Welding procedures approved	6.13.3.6			
	Welding repairs approved	6.13.3.6			
	Welding repair maps	6.13.3.6			
	Rotor balancing	6.8.1.9			
	Complete unit test	8.3.7.2			
	Sound level test	8.3.7.3			
	High discharge pressure test	8.3.7.4			

^a Check against certified dimensional outline drawing.

Annex D **(informative)**

Contract Documents and Engineering Design Data

D.1 Title

When specified by the purchaser in Section 9.1.2, the contract documents and engineering design data shall be supplied by the vendor, as listed in this annex.

D.1.1 The following data shall be identified with the following information on transmittal (cover) letters, title pages and correspondence:

- a) purchaser's/owner's corporate name;
- b) job/project number;
- c) equipment item number and service name;
- d) inquiry or purchase order number;
- e) any other identification specified in the inquiry or purchase order;
- f) vendors' identifying proposal number, shop order number, serial number, or other reference required to completely identify return correspondence.

D.1.2 Each drawing shall have a title block in the lower right-hand corner with the date of certification, identification data specified in D.1.1, revision number and date and title. Similar information shall be provided on all other documents including sub-vendor items.

D.2 Proposals

D.2.1 General

D.2.1.1 The vendor shall forward the original proposal, with the specified number of copies, to the addressee specified in the inquiry documents.

D.2.1.2 The proposal shall include, as a minimum, the data specified in D.2.2 through D.2.5, and a specific statement that the equipment and all its components and auxiliaries are in strict accordance with this standard.

D.2.1.3 If the equipment or any of its components or auxiliaries is not in strict accordance, the vendor shall include a list that details and explains each deviation.

D.2.1.4 The vendor shall provide sufficient detail to enable the purchaser to evaluate any proposed alternative designs.

D.2.1.5 All correspondence shall be clearly identified in accordance with D.1.2.

D.2.2 Drawings

D.2.2.1 The drawings indicated on the Vendor Drawing and Data Requirements (VDDR) form in this annex shall be included in the proposal. As a minimum, the following shall be included:

- a) a general arrangement or outline drawing for each machine train or skid-mounted package, showing overall dimensions, maintenance clearance dimensions, overall weights, erection weights, and the largest maintenance weight for each item. The direction of rotation and the size and location of major purchaser connections shall also be indicated;
- b) cross-sectional drawings showing the details of the proposed equipment;
- c) schematics of all auxiliary systems including fuel, lube oil, control, and electrical systems;
- d) bills of material;
- e) sketches that show methods of lifting the assembled machine or machines, packages, and major components and auxiliaries. (This information may be included on the drawings specified in item a above.)

D.2.2.2 If "typical" drawings, schematics, and bills of material are used, they shall be marked up to show the weight and dimension data to reflect the actual equipment and scope pro-posed.

D.2.3.1 All technical data shall be given in units of measurement according to the purchase order. If needed, the technical data in alternate units can be included in parentheses.

D.2.3.2 The following data shall be included in the proposal.

- a) purchaser's data sheets with complete vendor's information entered thereon and literature to fully describe details of the offering;
- b) predicted noise data (6.1.8.2);
- c) VDDR form (or equivalent listing) indicating the schedule according to which the vendor agrees to transmit all the data specified;
- d) schedule for shipment of the equipment, in weeks after receipt of an order;
- e) list of major wearing components, showing any interchangeability with the owner's existing machines;
- f) list of spare parts recommended for start-up and normal maintenance purposes;
- g) list of the special tools furnished for maintenance;
- h) description of any special weather protection and winterization required for start-up, operation, and periods of idleness, under the site conditions specified on the data sheets. This description shall clearly indicate the protection to be furnished by the purchaser as well as that included in the vendor's scope of supply;
- i) complete tabulation of utility requirements, e.g. steam, water, electricity, air, gas, lube oil (including the quantity and supply pressure of the oil required, and the heat load to be removed by the oil), and the nameplate power rating and operating power requirements of auxiliary drivers. Approximate data shall be clearly indicated as such;
- j) description of any optional or additional tests and inspection procedures for materials as required by 6.11.1.4;
- k) description of any special requirements, whether specified in the purchaser's inquiry or as outlined in 6.10.2.1, 6.11.1.2, 6.11.1.5, and 7.11.5;

- l) a list of machines, similar to the proposed machine(s), that have been installed and operating under conditions analogous to those specified in the inquiry;
- m) any start-up, shutdown, or operating restrictions required to protect the integrity of the equipment;
- n) a list of any components that can be construed as being of alternative design, hence requiring purchaser's acceptance (6.1.1.3);
- o) component designed for a finite life (6.1.2).

D.2.4 Curves

The vendor shall provide complete performance curves to encompass the map of operations, with any limitations indicated thereon.

D.2.5 Optional Tests

The vendor shall furnish an outline of the procedures to be used for each of the special or optional tests that have been specified by the purchaser or proposed by the vendor.

D.3 Engineering Design Data

D.3.1 General

D.3.1.1 Engineering data shall be furnished by the vendor in accordance with the agreed VDDR form.

NOTE Typical VDDR form can be modified by the purchaser to match the specific inquiry requirements.

D.3.1.2 The purchaser shall review the vendor's data upon receipt; however, this review shall not constitute permission to deviate from any requirements in the order unless specifically agreed in writing. After the data have been reviewed and accepted, the vendor shall furnish certified copies in the quantities specified.

D.3.1.3 A complete list of vendor data shall be included with the first issue of major drawings. This list shall contain titles, drawing numbers, and a schedule for transmittal of each item listed. This list shall cross-reference data with respect to the VDDR form.

D.3.2 Drawings and Technical Data

The drawings and data furnished by the vendor shall contain sufficient information so that together with the manuals specified in D.3.5, the purchaser can properly install, operate, and maintain the equipment covered by the purchase order. All contract drawings and data shall be clearly legible (8-point minimum font size even if reduced from a larger size drawing), shall cover the scope of the agreed VDDR form, and shall satisfy the applicable detailed descriptions in this annex.

D.3.3 Progress Reports

The vendor shall submit progress reports to the purchaser at intervals specified which shall, as a minimum, include the following:

- a) overall progress summary,

- b) status of engineering,
- c) status of document submittals,
- d) status of major suborders,
- e) updated production schedule,
- f) inspection/testing highlights for the month,
- g) any pending issues.

D.3.4 Parts Lists and Recommended Spares

D.3.4.1 The vendor shall submit complete parts lists for all equipment and accessories supplied.

D.3.4.1.1 These lists shall include part names, manufacturers' unique part numbers and materials of construction (identified by applicable international standards).

D.3.4.1.2 Each part shall be completely identified and shown on appropriate cross-sectional, assembly-type cutaway or exploded-view isometric drawings.

D.3.4.1.3 Interchangeable parts shall be identified as such.

D.3.4.1.4 Parts that have been modified from standard dimensions or finish to satisfy specific performance requirements shall be uniquely identified by part number.

D.3.4.2 The vendor shall indicate on each of these complete parts lists all those parts that are recommended as start-up or maintenance spares, and the recommended stocking quantities of each. These shall include spare parts recommendations of sub-vendors that were not available for inclusion in the vendor's original proposal.

D.3.5 Installation, Operation, Maintenance, and Technical Data Manuals

D.3.5.1 General

The vendor shall provide sufficient written instructions and all necessary drawings to enable the purchaser to install, operate, and maintain all of the equipment covered by the purchase order. This information shall be compiled in a manual or manuals with a cover sheet showing the information listed in D.1.2, an index sheet, and a complete list of the enclosed drawings by title and drawing number. The manual pages and drawings shall be numbered. The manual or manuals shall be prepared specifically for the equipment covered by the purchase order. "Typical" manuals are unacceptable.

D.3.5.1.1 A draft manual(s) shall be issued to purchaser eight weeks prior to mechanical testing for review and comment.

D.3.5.1.2 Refer to the VDDR Form for number of copies. Hard copies as well as electronic copies shall be provided as described on VDDR.

D.3.5.2 Installation Manual

D.3.5.2.1 All information required for the proper installation of the equipment shall be compiled in a manual that shall be issued no later than the time of issue of final certified drawings. For this reason, it may be separate from the operating and maintenance instructions.

D.3.5.2.2 This manual shall contain information on alignment and grouting procedures, normal and maximum utility requirements, centers of mass, rigging provisions and procedures, and all other installation data.

D.3.5.2.3 All drawings and data specified in D.2.2 and D.2.3 that are pertinent to proper installation shall be included as part of this manual.

D.3.5.2.4 One extra manual, over and above the specified quantity, shall be included with the first equipment shipped.

D.3.5.2.5 All recommended receiving and storage procedures shall be included.

NOTE Refer to API 686 for data required for installation.

D.3.5.3 Operating and Maintenance Manual

A manual containing all required operating and maintenance instructions shall be supplied at shipment. In addition to covering operation at all specified process conditions, this manual shall also contain separate sections covering operation under any specified extreme environmental conditions.

D.3.5.4 Technical Data Manual

The vendor shall provide the purchaser with a technical data manual at shipment.

Annex E (informative)

Rotary Pump Vendor Drawing and Data Requirements (VDDRs)

E.1 Pump

E.1.1 Reference Descriptions

- 1) Certified dimensional outline drawing and list of connections, including the following:
 - a) size, rating, and location of all customer connections;
 - b) approximate overall handling weights;
 - c) overall dimensions;
 - d) shaft centerline height;
 - e) dimensions of baseplates (if furnished), complete with diameter, number, and locations of bolt holes and thickness of the metal through which the bolts pass; centers of gravity; and details for foundation design;
 - f) grouting details;
 - g) forces and moments for suction and discharge nozzles;
 - h) center of gravity and lifting points;
 - i) shaft end separation and alignment data;
 - j) direction of rotation.
- 2) Cross-sectional drawing and bill of materials, including the following:
 - a) journal-bearing shaft and housing fits and tolerances;
 - b) rolling element bearing shaft and housing fits and tolerances;
 - c) shaft end details, fits and tolerances.
- 3) Mechanical seal drawings and bill of materials.
- 4) Primary and auxiliary sealing schematic and bill of materials, including seal fluid, fluid flows, pressure, pipe and valve sizes, instrumentation, and orifice sizes.
- 5) Cooling or heating schematic and bill of materials, including cooling or heating media, fluid flows, pressure, pipe and valve sizes, instrumentation, and orifice sizes.
- 6) Rotor assembly drawings and bills of materials, including the following items.
 - a) Axial position from the active thrust-collar face to:
 - i. each journal-bearing centerline,

-
- ii. coupling face or end of shaft.
 - b) Thrust-collar assembly details, including:
 - i. collar-shaft, with tolerance;
 - ii. concentricity (or axial runout) tolerance;
 - iii. required torque for locknut;
 - iv. surface finish requirements for collar faces;
 - v. preheat method and temperature requirements for shrunk-on collar installation.
 - 7) Thrust-bearing assembly drawing and bill of materials.
 - 8) Journal-bearing assembly drawings and bills of materials for all field-maintainable rotors.
 - 9) Shaft-coupling assembly drawings and bills of materials, including the following:
 - 1) hydraulic mounting procedure (if applicable),
 - 2) shaft end gap and tolerance,
 - 3) coupling guards.
 - 10) Lube-oil schematic and bills of materials, including the following:
 - a) steady-state and transient oil flows and pressures at each use point;
 - b) control, alarm, and trip settings (pressures and recommended temperatures);
 - c) total heat loads;
 - d) utility requirements, including electricity, water, and air;
 - e) pipe, valve, and orifice sizes;
 - f) instrumentation, safety devices, control schemes and wiring diagrams;
 - g) lubricating oil system arrangement drawing, including size, rating, and location of all purchaser connections;
 - h) lubricating oil component drawings and data, including the following:
 - i. pumps and drivers;
 - ii. coolers, filters, and reservoir;
 - iii. instrumentation;
 - iv. spare parts lists and recommendations.
 - 11) Electrical and instrumentation schematics and bills of materials for all systems. The schematics shall show the alarm and shutdown limits (set points) below:
 - a) vibration alarm and shutdown limits;

-
- b) bearing temperature alarm and shutdown limits;
 - c) lubricating oil temperature alarm and shutdown limits;
 - d) driver.
- 12) Electrical and instrumentation assembly drawings and lists of connections.
 - 13) Tabulation of utility requirements (may be on as-built purchaser datasheets).
 - 14) Curve showing output-power shaft speed vs torque.
 - 15) Anticipated thermal movements referenced to a defined point.
 - 16) Coupling alignment diagram, including recommended coupling limits during operation. Note all shaft-end position changes and support growth from a reference ambient temperature of 15 °C (59 °F) or another temperature specified by the purchaser. Include the recommended alignment method and cold setting targets.
 - 17) Welding procedures for fabrication and repair.
 - 18) Vibration analysis data.
 - 19) Damped unbalanced response analysis.
 - 20) Lateral Critical Speed Analysis—The required number of lateral critical analysis reports, no later than three months after the date of order.
 - 21) Torsional Critical Speed Analysis—The required number of torsional critical analysis reports, no later than three months after the date of order.
 - 22) Certified hydrostatic test data/logs.
 - 23) Mechanical running test logs.
 - 24) Performance test logs and report.
 - 25) Nondestructive test procedures as itemized on the purchase order datasheets or the VDDR form.
 - 26) Procedures for any special or optional tests.
 - 27) CMTR's of items as agreed upon in the pre-commitment or pre-inspection meetings.
 - 28) As-built datasheets.
 - 29) As-built dimensions (including nominal dimensions with design tolerances) and data for the following listed parts.
 - a) Shaft or sleeve diameters at:
 - i. thrust collar (for separate collars),
 - ii. each seal component,
 - iii. each journal bearing.
 - b) Each labyrinth or seal-ring bore.

-
- i. Thrust-collar bore (for separate collars).
 - ii. Each journal-bearing inside diameter.
 - iii. Thrust-bearing concentricity (axial run-out).
 - iv. Metallurgy and heat treatment of:
 - shaft,
 - rotors,
 - thrust collar.
- 30) Installation manual describing the following:
- a) storage procedures including winterization, tropicalization if required;
 - b) foundation plan;
 - c) grouting details;
 - d) setting equipment, rigging procedures, component weights, and lifting diagrams;
 - e) coupling alignment diagram [per Item 13)];
 - f) piping recommendations, including allowable flange loads;
 - g) composite outline drawings for the driver/driven-equipment train, including anchor bolt locations;
 - h) dismantling clearances;
 - i) noise attenuation details.
- 31) Operating and maintenance manuals describing the following items:
- a) start-up;
 - b) normal shutdown;
 - c) emergency shutdown;
 - d) lube-oil recommendations;
 - e) routine operational procedures, including recommended inspection schedules and procedures;
 - f) instructions for:
 - i. disassembly and reassembly of journal bearings (for tilting-pad bearings, the instructions shall include “go/no-go” dimensions with tolerances for three-step plug gauges);
 - ii. disassembly and reassembly of thrust bearing;
 - iii. disassembly and reassembly of seals (including maximum and minimum clearances);
 - iv. disassembly and reassembly of thrust collar.

- g) Performance data, including:
 - i. curve showing certified shaft speed vs site rated power;
 - ii. curve showing output-power shaft speed vs torque.
 - h) As-built data, including:
 - i. as-built datasheets;
 - ii. as-built dimensions or data, including assembly clearances;
 - iii. hydrostatic test logs, per Item 15);
 - iv. mechanical running test logs, per Item 16).
 - i) Drawings and data, including:
 - i. dimensional outline drawing and list of connections;
 - ii. cross-sectional drawing and bill of materials;
 - iii. rotor assembly drawings and bills of materials;
 - iv. thrust-bearing assembly drawing and bill of materials;
 - v. journal-bearing assembly drawings and bills of materials;
 - vi. seal-component drawing and bill of materials;
 - vii. lube-oil schematics and bills of materials;
 - viii. electrical and instrumentation schematics and bills of materials;
 - ix. electrical and instrumentation assembly drawings and list of connections.
- 32) Spare parts list with stocking level recommendations.
- 33) Progress reports and delivery schedules, including vendor buy-outs and milestones. progress reports detailing the cause of any delays: the reports shall include engineering, purchasing, manufacturing, and testing schedules for all major components. Planned and actual dates, and the percentage completed, shall be indicated for each milestone in the schedule.
- 34) List of drawings, including latest revision numbers and dates.
- 35) Shipping list, including all major components that will ship separately.
- 36) List of special tools furnished for maintenance.
- 37) Technical data manual, including the following:
 - a) as-built purchaser datasheets, per Item 21);
 - b) certified performance curves, per Item 17);
 - c) drawings;

- d) as-built assembly clearances;
 - e) spare parts list;
 - f) utility data, per Item 13);
 - g) reports, per Item 17);
- 38) Material safety datasheets (OSHA Form 20).

E.2 Driver and Gear (if Applicable)

E.2.1 Reference Description

- 1) Certified dimensional outline drawing for motor and all auxiliary equipment, including the following:
 - a) size, location, and purpose of all purchaser connections, including conduit, instrumentation, and any piping or ducting;
 - b) ASME rating and facing for any flanged connections;
 - c) size and location of anchor bolt holes and thicknesses of sections through which bolts pass;
 - d) total mass of each item of equipment (motor and auxiliary equipment) plus loading diagrams, heaviest mass, and name of the part;
 - e) overall dimensions and all horizontal and vertical clearances necessary for dismantling, and the approximate location of lifting lugs;
 - f) shaft centerline height;
 - g) shaft end dimensions, plus tolerances for the coupling;
 - h) direction of rotation.
- 2) Cross-sectional drawing and bill of materials, including the axial rotor float.
- 3) Datasheets applicable to proposals, purchase, and as-built.
- 4) Noise datasheets.
- 5) For induction motors 150 kW (200 hp) and smaller:
 - a) efficiency and power factor at one-half, three-quarter, and full load;
 - b) speed-torque curves.
- 6) For induction motors larger than 150 kW (200 hp) and larger, certified test reports including the following:
 - a) time-current heating curve;
 - b) speed-torque curves at 70 %, 80 %, 90 %, and 100 % of rated voltage;
 - c) efficiency and power factor curves from 0 to rated service factor;

-
- d) current vs load curves from 0 to rated service;
 - e) current vs speed curves from 0 % to 100 % of rated speed.
- 7) Certified drawings of auxiliary systems, including wiring diagrams, for each auxiliary system supplied. The drawings shall clearly indicate the extent of the system to be supplied by the vendor and the extent to be supplied by others.
- 8) Driver instruction manuals describing installation, operating and maintenance procedures. Each manual shall include the following sections:
- a) Section 1—Installation:
 - i. storage;
 - ii. setting motor, rigging procedures, component masses and lifting diagram;
 - iii. piping and conduit recommendations;
 - iv. composite outline drawing for motor, including locations of anchor-bolt holes;
 - v. dismantling clearances.
 - b) Section 2—Operation:
 - i. start-up, including check before start-up;
 - ii. normal shutdown;
 - iii. operating limits, including number of successive starts;
 - iv. lubricating oil recommendations.
 - c) Section 3—Disassembly and assembly instructions:
 - i. rotor in driver,
 - ii. journal bearings,
 - iii. seals,
 - iv. routine maintenance procedures and intervals.
 - d) Section 4—Performance data required;
 - e) Section 5—Datasheets:
 - i) as-built datasheets;
 - ii) noise datasheets.
 - f) Section 6—Drawing and data requirements:
 - i. certified dimensional outline drawing for motor and all auxiliary equipment, with list of connections;
 - ii. cross-sectional drawing and bill of materials;

- iii. spare parts recommendations and price list;
- iv. material safety datasheets.

ANNEX E—ROTARY PUMP													
JOB NO.													
PURCHASE ORDER NO.													
VENDOR DRAWING & DATA REQUIREMENTS													
REQUISITION NO.						DATE							
INQUIRY NO.						DATE							
API 676 4 th Edition—Rev 1													
PAGE			OF			BY							
REVISION						DATE							
UNIT						DATE							
NO. REQUIRED						DATE							
SERVICE													
Bidder shall email pdf files of all items indicated by an X.													
Vendor shall email pdf files of drawings and data indicated.													
Vendor shall email pdf files of drawings and data indicated.													
Vendor shall email pdf files of drawings and data indicated.													
Vendor shall furnish _____ copies of operating and maintenance manuals / data books and _____ CDs of pdf files of same.													
DISTRIBUTION RECORD													
Final				Received from vendor									
Final				Due from vendor c									
Review				Returned from vendor									
Review				Received from vendor									
Review				Due from vendor c									

		Review – Received from vendor	Review – Due from vendor c
Note: Mark through those items that will not be furnished & add items that will.			
VDDR Note Ref. No.	Pump	DESCRIPTION	
E.1.1	Certified dimensional outline drawing		
E.1.1	Allowable flange loadings (can be part of certified outline drawing)		
E.1.2	Cross-sectional drawings and bills of materials		
E.1.3	Mechanical seal drawing and bills of materials		
E.1.9	Shaft coupling assembly drawing and bill of materials		
E.1.4	Primary and auxiliary flush piping schematics and bills of materials		
E.1.5	Cooling or heating schematic and bill of materials		
E.1.10	Lubricating oil schematic and bill of materials		
E.1.10	Lubricating oil system arrangement drawing		
E.1.10	Lubricating oil component drawings		
E.1.11	Electrical and instrumentation schematics, wiring diagrams, and bills of materials		
E.1.12	Electrical and instrumentation arrangement drawing and list of connections		
E.1.13	Tabulation of utility requirements		
E.1.14	Pump speed torque curve		
	Performance curves		
E.18	Vibration analysis data		
E.1.19	Damped unbalanced response analysis		
E.1.20	Lateral critical speed analysis		
E.1.21	Torsional critical speed analysis		
E.1.22	Certified hydrostatic test data		
E.1.28	Material certifications		
E.1.17	Weld procedures		
E.1.26	Non-destructive testing procedures		
E.1.27	Performance and optional test procedures		
E.1.25	Performance test data		

		E.3.8	Installation operation and maintenance manuals				
		E.3.8	Spare parts recommendations				
a Proposal drawings and data do not have to be certified or as-built. Typical data shall be clearly identified as such.							
b Purchaser will indicate in this column the time frame for submission of materials using the nomenclature given at the end of this form							
c Vendor shall complete these two columns to reflect his actual distribution schedule and include this form with his proposal							
Email all drawings and data to _____							
Ship final IOM's and Data books to: _____							
All drawings and data shall show project, appropriation, purchase order, and item numbers in addition to the plant location and unit. In addition to the copies specified above, one set of the drawings/instructions necessary for field installation shall be forwarded with the shipment.							
Nomenclature:							
S — number of weeks prior to shipment.							
F — number of weeks after firm order.							
D — number of weeks after receipt of approved drawings.							
Vendor: _____				Vendor Reference: _____			
Date: _____				_____			
Note: Vendor and purchaser to mark out items that do not apply to this order and sign below.							
Vendor Signature: _____				_____			
Purchaser Signature: _____				_____			

Annex F (informative)

Net Positive Suction Head (NPSH) vs Net Positive Inlet Pressure (NPIP)

F.1 General

Because centrifugal pumps and positive displacement pumps operate on entirely different principles, common usage has created two different ways to identify the pressures associated with them. In its simplest form, a centrifugal pump is a velocity generator, whereas the positive displacement pump is a flow generator. In the case of the centrifugal pump, the liquid to be pumped is directed into the center of a rotating impeller where it is guided by the impeller vanes and accelerated to a higher velocity. The casing surrounding the impeller then converts the high velocity into pressure. Because it is a velocity generator, if pressure is measured in units of liquid length, all units of measure become consistent. Velocity is measured in meters/second (feet/second) and discharge pressure is measured in meters (feet) of liquid (i.e. the pressure created by the height of a column of the liquid being pumped). This consistent use of units greatly simplifies pump calculations and allows the effects of certain liquid properties (e.g. relative density) to be ignored. For a centrifugal pump, the discharge pressure developed is a function of flow through the pump impeller. With decreasing flow (as in the case of increased system resistance), the centrifugal pump develops an ever increasing pressure up to the point defined as the shutoff head at zero flow. Shutoff head is normally the maximum pressure rise that a centrifugal pump can develop, but there are instances when the shutoff head is less than the maximum head generated by the pump.

F.2 Rotary PD

By contrast, a rotary positive displacement pump does not generate energy solely by increasing fluid velocity. Instead, these pumps convert rotary motion and torque into constant linear fluid motion and force, generating a fixed flow rate at the discharge connection. Positive displacement pumps have no theoretical discharge pressure limitation. They respond solely to the pumping system, and require system discharge control, usually in the form of a PLV, to prevent damage to the pump mechanism, the pumping system, or stalling of the driver. For a positive displacement pump, flow is a function of pump displacement and rpm.

F.3 Suction Pressure—Centrifugal and Rotary PD

Both types of pumps require sufficient fluid pressure at the inlet to prevent a release of dissolved gases or a change in the state of the pumped fluid from liquid to gas, except for MPPs. The term for pressure at the inlet is either NPSH or NPIP. To be consistent, the API standards for both centrifugal and rotary pumps, as well as the latest editions of the Hydraulic Institute standards, refer to the total suction head as NPSH rather than NPIP. Although the Hydraulic Institute indicates that NPSH is normally expressed in either kilopascals (pounds force per square inch) or meters (feet), the latest API standards refer to NPSH in meters (feet), the preferred unit terminology for both pump types, to avoid confusion.

F.4 Rotary PD Equations

Positive displacement pump vendors generally refer to NPIP, expressed in kilopascals (pounds force per square inch). ISO 16330 also uses the term NPIP rather than NPSH. NPSH or NPIP is indicated as either “available” (NPSHA or NPIPA) or “required” (NPSHR or NPIPR). The net positive inlet pressure available (NPIPA) is the absolute pressure above fluid vapor pressure at the pump inlet, and is determined as follows:

$$NPIPA = p_a + p_z - p_f - p_{vp}$$

where

p_a	is the absolute pressure at surface of liquid, expressed in kilopascals (pounds force per square inch) at the altitude of the installation;
p_z	is the static head (+) or static lift (–), expressed in kilopascals (pounds force per square inch), for level of fluid above or below inlet;
p_f	is the inlet line, valve, and fitting friction losses at maximum viscosity, expressed in kilopascals (pounds force per square inch);
p_{vp}	is the fluid vapor pressure or gas dissolution pressure, expressed in kilopascals (pounds force per square inch);

NPIPR is a function of pump type, speed and viscosity of fluid pumped. The NPIPA shall always be greater than NPIPR to prevent occurrence of cavitation.

Annex G (informative)

Typical P&D for MPP Pumps

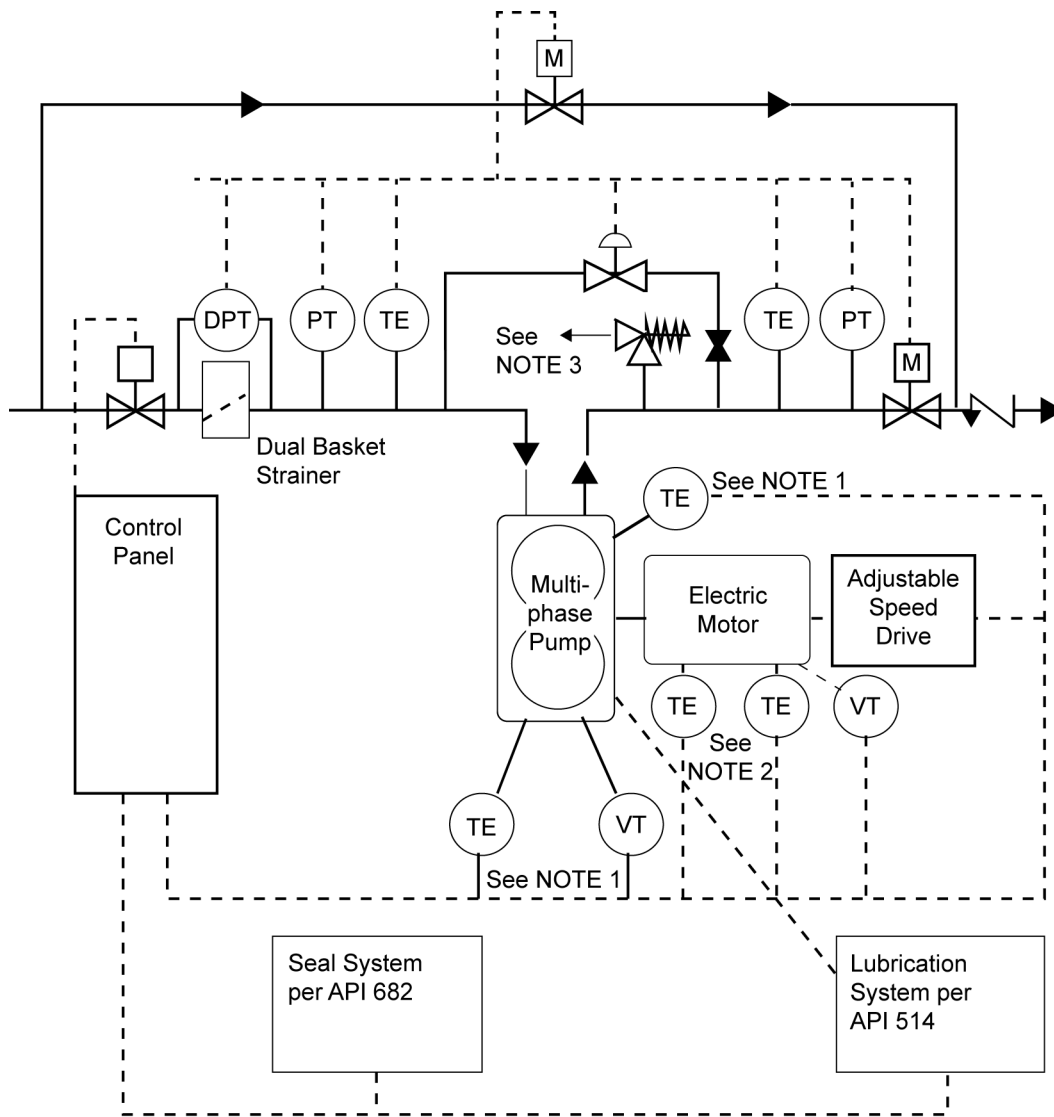

- NOTE 1 Pump TE covers bearing and fluid discharge.
 NOTE 2 Motor TE covers windings and bearings.
 NOTE 3 Discharge from the pressure limiting valve shall be piped to a suction vessel, or header, or as far upstream of the skid as practical.
 NOTE 4 Manual valves and small piping are not shown for clarity purposes.

Bibliography

- [1] AGMA 2015-1,¹ *Accuracy Classification System—Tangential Measurements for Cylindrical Gears*
- [2] ASME B16.20, *Metallic Gaskets for Pipe Flanges—Ring-joint, Spiral-wound and Jacketed*
- [3] EN 288, *Specification and Approval of Welding Procedures for Metallic Materials*

¹ American Gear Manufacturers Association, 500 Montgomery Street, Suite 350, Alexandria, Virginia 22314, www.agma.org.



200 Massachusetts Avenue, NW
Suite 1100
Washington, DC 20001-5571
USA

202-682-8000

Additional copies are available online at www.api.org/pubs

Phone Orders: 1-800-854-7179 (Toll-free in the U.S. and Canada)
303-397-7956 (Local and International)
Fax Orders: 303-397-2740

Information about API publications, programs and services is available on the web at www.api.org.

Product No. C67604